

Canon

EOS 5D Mark II

EOS 5D

WHITE PAPER



**THE CANON
EOS 5D CAMERA:
UNPRECEDENTED
FLEXIBILITY OF DIGITAL
PHOTOGRAPHY**



**THE CANON
EOS 5D MARK II CAMERA:
HIGH PERFORMANCE FOR
HIGH EXPECTATIONS**

I.	Overview	4
II.	Summary of New and Improved Features	8
	EOS 50D vs. EOS 40D	9
	EOS 5D Mark II vs. EOS 5D	10
	EOS 5D Mark II vs. EOS-1Ds Mark III	11
III.	Video Recording on EOS 5D Mark II	13
	Features and Benefits	14
	Positioning	16
	Tech Info	18
	Technology Highlight - New Video Shooting Capability	19
IV.	Performance and Reliability	20
	Advanced Sensor Designs	21
	DIGIC 4 and 14-bit A/D Conversion	23
	Image Recording and Processing	25
	• RAW, sRAW, RAW+JPEG	25
	• Intelligent Lithium-ion Battery on EOS 5D Mark II	26
	Image Enhancement	26
	• High ISO Noise Reduction	26
	• Peripheral Illumination Correction	27
	• Auto Lighting Optimizer	28
	• Highlight Tone Priority	28
	High Resolution, 3.0-inch Clear View LCD	29
	Live View shooting with AF	30
	Precise 9-point AF Systems	31
	Improved Viewfinder Experience	33
	Rugged Construction	33
	EOS Integrated Cleaning System	34
	Intuitive Button and Dial Arrangement	35
	Increased Shutter Durability	35
	Action-stopping Burst Modes	36
	UDMA Compatibility	36
	HDMI Connectivity	36
	Technology Highlight - Live View Function	38
V.	Controls and Convenience	39
	Camera Settings and Displays	40
	Creative Auto Mode	40
	Image Quality Controls	42
	Playback Controls and Displays	42
	My Menu and User Settings	43
	Custom Function Controls	43
	AF Microadjustment	44
	Quick Control Screen	45
	Printing and Camera Direct Controls	45

VI. Intelligent Bundled Software	46
New Features in EOS Utility and DPP	47
VII. New Accessories and Lenses	48
Battery Grips	49
Wireless File Transmitters	50
EF 24mm f/1.4L II USM lens	51
EF-S 18-200mm f/3.5-5.6 IS lens	52
VIII. Specifications	54
EOS 50D	55
EOS 5D Mark II	60
EF 24mm f/1.4L II USM Wide Angle lens	68
EF-S 18-200mm f/3.5-5.6 IS Wide Angle-Telephoto Zoom lens	69
IX. Feature Comparison Charts	70
EOS 50D vs. EOS 40D	71
EOS 5D Mark II vs. EOS 5D	73
X. Conclusion	76





Great photographers know that one of the secrets to capturing exceptional photos is to match the camera, lens, and accessories to the photo assignment at hand. But budget also plays an important role in maintaining a competitive advantage, especially for advanced and semi-professional photographers fighting for the recognition they deserve. That's why Canon's newest DSLRs, the EOS 50D and EOS 5D Mark II are designed, built, and priced to appeal to a wide range of serious photographers, with groundbreaking features inspired by creative professionals.

Both cameras inherit the rugged bodies, exceptional performance, and enduring value that made the EOS 40D and EOS 5D two of the top-selling DSLRs in their categories. In keeping with Canon's history of technology advancements and unrivaled control over the manufacturing process from integrated circuits to optical coatings, the EOS 50D, at around \$1,400, and the EOS 5D Mark II, at around \$2,700, are priced similarly or well below the introductory prices of their predecessors. Yet both offer improved image quality, higher precision AF systems, and a host of exciting new features.

The EOS 50D's 15.1-megapixel, high sensitivity CMOS sensor, designed with an improved EOS Integrated Cleaning System to resist dust, offers exceptional resolution, image quality, and low-light performance for an APS-C sized imaging sensor. Its 14-bits per channel of RAW data is masterfully converted into more natural colors, finer color gradations, razor-sharp detail, and extraordinarily low noise images by Canon's state-of-the-art DIGIC 4 Image Processor. The processing prowess of the DIGIC 4 Image Processor also enables the EOS 50D's 6.3 fps burst rate at full resolution as well as a new suite of sophisticated — and automatic — image enhancement features.

The EOS 5D Mark II camera breaks new ground for a full-frame DSLR. It shares 80% of its features with the EOS 5D, and 10% with the flagship Canon EOS-1Ds Mark III (including a Full-frame 21.1-megapixel sensor and bright, full coverage optical viewfinder). However, the EOS 5D Mark II's 21.1-megapixel sensor is unique and offers an exciting feature found on no other DSLR to date—30 fps, 1080p Full HD video recording with sound! The 1080p HD video recording mode represents a paradigm shift for still photographers and videographers alike, and promises to open new creative doors and commercial opportunities for advanced, professional, and fine art photographers. With it activated, photographers and videographers can capture high definition video with depth-of-field control found only in professional video models—using much more affordable Canon EF lenses including fisheye, ultra-wide, and image stabilized lenses.



1080p HD Video

To accommodate the larger 36mm x 24mm full-frame sensor, the EOS 5D Mark II sports an improved optical viewfinder with an impressive 98% coverage. In concert with the new sensor and integrated DIGIC 4 Image Processor, the EOS 5D Mark II gives photographers unparalleled opportunity to capture images with superb tonal gradations, extended dynamic range, and a low signal-to-noise ratio—allowing normal ISO settings up to 6400, and expanded ISO settings up to 25,600. The DIGIC 4 Image Processor enables faster startup times and a 3.9 fps burst rate with continuous capture of 21.1-megapixel JPEGs limited only by the capacity of the memory card when using UDMA-compliant CF cards. Advanced in-camera functions similar to those found in the provided Digital Photo Professional RAW conversion software are also a benefit of the DIGIC 4 Image Processor and include Peripheral Illumination Correction, High ISO Noise Reduction and Auto Lighting Optimizer.



EOS 5D's 3.0-inch LCD

Both of the new EOS models now feature multi-coated 3.0-inch LCDs with 920,000-dot resolution—displaying nearly four times the detail as those found on previous Canon DSLRs. The LCDs also feature improved dirt resistance, menu readability, reduced reflectivity for enhanced viewing in bright light, and 100% scene coverage to assist manual focusing and composition in Live View mode. For novices getting the feel of the EOS 5D or EOS 5D Mark II, the new Quick Control screen lets you make common exposure and image quality adjustments from just one screen, or you can use the screen to modify settings in the Creative Auto settings mode.

Both EOS cameras offer Quick and Live AF modes that work in Live View mode, including a Face Detection AF mode that optimizes exposure and focus for a selected face. Faster AF speed and tracking is possible when using the viewfinder in either camera. The EOS 5D Mark II's 9 AF points are arranged in a diamond-shaped array within the

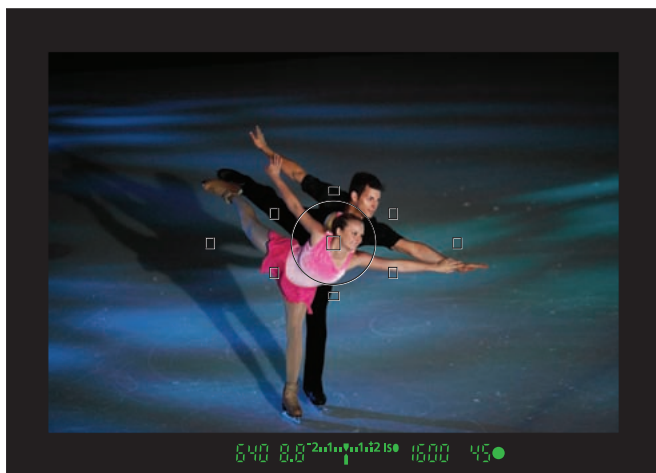

EOS 5D Mark II's Viewfinder

viewfinder for improved horizontal and vertical focus coverage and tracking. Eight of the AF points are horizontal-line sensitive with $f/5.6$ or brighter lenses, while the center point is a cross type with vertical line sensitivity with $f/2.8$ or brighter lenses. These selectable, and visible 9 AF points are assisted by six invisible supplemental AF Assist Points that can combine with the center AF point to increase its size when tracking fast moving subjects.

The autofocus engine on the EOS 50D also includes 9 cross-type AF points in a diamond array, with eight providing horizontal and vertical sensitivity with $f/5.6$ or brighter lenses, and a unique diagonal, high precision center sensor that works with $f/2.8$ or brighter lenses. In addition, both the EOS 50D and EOS 5D Mark II AF systems, like Canon's latest 1D-series professional models, can now correct for focus point shifts caused by different light sources, and feature an AF Microadjustment setting to help fine tune individual Canon EF lenses.

The EOS 50D will suit the needs of advanced photographers looking for an extremely durable and affordable camera that also features incredible image quality, fast capture, a precision AF system, and an integrated pop-up flash system. Serious photographers and pros looking to capture images with incredible detail, wider fields of view and extreme low light scenes will find the extra cost of the EOS 5D Mark II well worth it. Add in the 1080p HD video recording and the EOS 5D Mark II can't be beat at any price.



EOS 50D vs. EOS 40D

- **15.1 Megapixel CMOS sensor** (APS-C size) with improved microlens design for superior image quality
- Advanced **DIGIC 4 Image Processor** for faster image processing and writing
- Approx. 6.3 fps continuous shooting even at maximum image size with bursts up to 90 shots (JPEG, Large/Fine in high-speed continuous mode using UDMA CF card), up to 16 shots in RAW, and up to 10 shots in RAW+JPEG Large/Fine
- Normal ISO range from ISO 100 to 3200, with expanded ISO range from 6400 to 12,800
- Fortified moisture and dust seals around battery compartment and memory card compartment
- Improved long exposure noise reduction, and high ISO noise reduction with Standard, Low, Strong, or Disabled settings
- Support for high speed **UDMA-compliant CF** cards
- **Peripheral Illumination Correction** compensates for light falloff, using optical characteristics of up to 40 Canon lenses stored in camera
- Improved **EOS Integrated Cleaning System** with Fluorine coated low-pass filter and manual control of Self Cleaning Sensor Unit activation
- Optical viewfinder data now includes camera shake warning symbol, accepts 3 optional interchangeable focusing screens
- **AF Microadjustment** setting now included in Custom Functions
- EOS 50D's 3.0-in., Clear View LCD with **920,000-dot** resolution, 100% coverage, and a wider viewing angle (approx. 170° vertical and horizontal)
- LCD includes dirt and smudge resistant Fluorine coating and anti-reflective coatings
- **Quick Control** screen displays essential camera settings in one window, with single press of rear 8-way multi-controller
- Live View Function with Silent shooting mode and 3 AF modes: **Quick AF** uses the camera's 9 AF points with a momentary interruption of live viewing. **Live AF** mode uses contrast detection with an AF frame that can be moved around the image area. **Face Detection AF** locks in on detected faces in scene and can be set to desired face
- Two different framing grids are provided for improved Live View composition
- Support for reduced-resolution sRAW1 (7.1 megapixel) and sRAW2 (3.8 megapixel) files
- Improved **Auto Lighting Optimizer** (ALO) and Highlight Tone Priority settings
- **Creative Auto** exposure mode allows intuitive adjustment of settings
- Higher degree of customization with 25 Custom Functions and 72 possible settings
- **HDMI** connectivity allows you to view your still photos or slide shows on a High Definition TV or projection system. Output resolution is set automatically to HDTV model
- Compatible with EF and EF-S lenses, including new compact EF-S 18–200mm f/3.5–5.6 IS lens with in-lens Optical Image Stabilizer

- Accepts optional **Battery Grip BG-E2N** with capability to house 2 BP-511A lithium-ion batteries or 6 AA/LR-6 batteries (same as EOS 40D)
- Compatible with compact **Wireless File Transmitter WFT-E3A** which connects camera to wireless and wired LAN networks, or to USB drives and GPS units (same as EOS 40D)
- Switch to registered AF point is possible (Home Position function)

EOS 5D Mark II vs. EOS 5D

- **21.1 Megapixel CMOS sensor** (Full-frame, 36mm x 24mm). Canon-designed and manufactured with improved microlens design and 6.4 micron pixels for superior image quality 0.76x viewfinder magnification (approx. 35° angle of view), approx. 20mm eyepoint
- Advanced **DIGIC 4 Image Processor** provides faster image processing and card writing speed, plus faster 0.1 sec. startup time
- 14 bits per color A/D conversion in DIGIC 4 Image Processor yields finer gradations, more accurate colors, and improved highlight and shadow details
- Recording and playback of 1080p Full HD video (1920 x 1080 pixels per frame at 30 fps) with sound is now possible in Live View mode, a first for any EOS Digital SLR camera
- Built-in microphone records in mono; 3.5mm diameter stereo mini jack can be used to record from stereo audio sources
- Picture Style settings can be used in video recording mode
- Image Stabilized lenses can be used during HD video recording
- Basic ISO range 100~6400; ISO expansion setting extends ISO range from ISO 50 to 25,600
- Approx. 3.9 fps continuous shooting even at maximum image size with bursts limited only by memory card capacity (JPEG, Large/Fine images in high-speed continuous mode) when using a UDMA CF card or up to 14 in RAW, up to 13 in RAW+JPEG Large/Fine
- Continuous HD movie recording time up to approximately 12 minutes using a 4GB CF card
- New, more durable shutter rated to 150,000 shots for professional level usage
- Fortified moisture and dust seals around battery compartment, memory card compartment and multiple buttons
- Improved long exposure noise reduction, and high ISO noise reduction with Standard, Low, Strong, or Disabled settings
- Support for high speed **UDMA-compliant CF** cards
- **Peripheral Illumination Correction** compensates for light falloff, using optical characteristics of up to 40 Canon lenses stored in camera
- Improved **EOS Integrated Cleaning System** with Fluorine coated low-pass filter and manual control of Self Cleaning Sensor Unit activation
- Improved optical wide-coverage viewfinder covers 98% of scene, data now includes ISO speed, Highlight Tone Priority indicator (D+), monochrome: B/W, and Battery check indicators
- New Eg-series focusing screens include Precision Matte, Precision Matte with grid and Super Precision Matte

- Improved AF sensor with 9 visible and 6 invisible assist AF points now automatically corrects for shifts in focus due to different light sources
- AF Microadjustment setting for fine-tuning individual lenses is now included in Custom Functions
- New **AF Start** button for rapid activation of autofocus system
- Control button layout has been rearranged for more intuitive access on camera back and top
- 3.0-in. Clear View LCD with **920,000-dot** resolution, 100% coverage, and a wider viewing angle (approx. 170° vertical and horizontal)
- LCD features dirt and smudge resistant Fluorine coating and anti-reflective coatings
- **Quick Control** screen displays essential camera settings in one window
- Live View Function with Silent shooting mode and 3 AF modes: **Quick AF** uses the camera's 9 plus 6 AF points with a momentary interruption of live viewing. **Live AF** mode uses contrast detection AF with an AF box that can be moved around the image area. **Face Detection AF** locks in on the closest face (up to 35 faces are detectable) and can be set to follow desired face
- Newly developed 2 motor system drive powers shutter mechanism and mirror assemblies independently
- Support for reduced-resolution small RAW files: **sRAW1** (10 megapixels) and **sRAW2** (5.2 megapixels)
- Improved Auto Lighting Optimizer (ALO) and Highlight Tone Priority settings
- Higher degree of customization with 25 Custom Functions with 71 possible settings
- **HDMI** connectivity allows you to view your still photos or slide shows on a High Definition TV or projection system. Output resolution is set automatically to HDTV model
- Compatible with EF lenses, including new **EF 24mm f/1.4L II USM lens**
- New LP-E6 lithium-ion, 1800mAh smart battery provides data on remaining shot capacity, shutter count, and recharge performance
- Accepts new optional **Battery Grip BG-E6** with capability to house 2 smart LP-E6 lithium-ion batteries or 6 AA/LR-6 batteries
- Compatible with compact **Wireless File Transmitter WFT-E4A** which connects camera to wireless and wired LAN networks, or to USB drives and GPS units

EOS 5D Mark II vs. EOS-1Ds Mark III

- Both offer 21.1 Megapixel Full-frame CMOS sensors, but EOS 5D Mark II is priced nearly \$5,000 less than EOS-1Ds Mark III
- EOS 5D Mark II is lighter and more compact. The EOS-1Ds Mark II is built to tighter pro standards and includes a vertical grip and shutter release
- EOS 5D Mark II features 1080p Full HD video and sound recording
- Has HDMI output for viewing video and still images
- Has three AF modes in Live View Function: Quick AF, Live AF and Face Detection AF
- Uses single DIGIC 4 Image Processor with fast processing and writing

- Features normal ISO range from 100–6400, expanded ISO range from ISO 50 to 25,600
- EOS 5D Mark II's 3.0-in. LCD has higher 920,000-dot resolution and added coatings for smudge resistance and low reflectance
- Image processing features include Peripheral Illumination Correction and Auto Lighting Optimizer

III. VIDEO RECORDING ON EOS 5D MARK II



Features and Benefits

The EOS 5D Mark II's Full High Definition (HD) video recording and playback functionality is creating a paradigm shift in the way still photographers and videographers approach their craft. In the past, one camera or camcorder couldn't do it all, so advanced and professional photographers rarely thought outside of the still-picture box—and into the fluid motion world of video with sound. But as the thirst for video on the Internet expands and as news organizations tighten their budgets, it will be more cost effective to send one EOS 5D Mark II equipped photographer to an event or wedding instead of a still photographer and movie crew, or a single wedding photographer to capture the important moments in both formats, thus giving owners of the EOS 5D Mark II a distinct competitive advantage.



On the other hand, serious videographers rarely use their camcorders to capture still images—even though most modern camcorders have the ability. The reason? The average still frame taken by a camcorder (even an expensive 3-chip, HDTV model) is under 5.0-megapixels and may include image quality problems that show up in print. Unlike these camcorders, the 21.1-megapixel EOS 5D Mark II can capture extraordinary quality still images for print clients and even expand the creative possibilities when recording HD video clips. It's lighter, smaller, and lower-priced than most professional HD camcorders, yet provides amazing depth-of-field control, exposure compensation and white balance controls, and full compatibility with Canon's super-telephoto, macro, fisheye, tilt-shift, soft focus, and image stabilized EF lenses.

Until now, there were no affordable 1080p HD video camcorders able to capture ultrawide or fisheye perspectives without the addition of distortion-producing adapter lenses, and none that had the depth-of-field control found in the EOS 5D Mark II. There are several reasons for this: all current 3-chip HD camcorders, even those costing over \$10,000, use 1/3-inch (or smaller) format sensors with pixels that are approximately 1/10 the size of those found in the EOS 5D Mark II. Pixel size primarily affects the light sensitivity and noise levels, with smaller pixels being less sensitive and producing higher noise. Using 3 sensors to capture individual RGB color channels helps to improve light sensitivity and reduce overall noise to some extent. But the sensor size affects the focal length required to deliver a normal zoom range, and because of the small sensor size, most camcorders feature lenses with focal lengths that start around 5mm and extend to 50mm (for a 10x zoom) or 100mm (for a 20x zoom that's roughly equivalent to 400mm focal length on a full-frame camera such as the EOS 5D Mark II). Depth of field at any given aperture increases as focal length decreases, so for most focal length positions on a typical HD camcorder, it's nearly impossible to blur background elements when shooting a portrait or closeup. On the other hand, even an EF 50mm f/1.4 USM lens mounted on an EOS 5D Mark II will provide narrower depth of field at all apertures compared

to the fully zoomed-in focal length on most camcorders. And few video cameras in existence can match the narrow depth of field of Canon's EF 85mm f/1.2L II USM lens used by many top-end portrait shooters. Because of these unique video recording traits and the versatility provided by Canon's EF lens system, the EOS 5D Mark II should be as attractive to serious videographers as it is to advanced and professional still photographers.

It may seem like a small technological advance to move from a full-frame DSLR model offering a Live View Function (such as the more expensive EOS 1Ds Mark III) to a full-frame DSLR offering both Live View and 1080p Full HD video recording functionality. But it was an engineering feat that only Canon, with its long history as a manufacturer of consumer and professional level camcorders, premium lenses for TV and broadcast cameras, and advanced CMOS sensors could achieve. Canon's knowledge of the real world challenges faced by videographers was also behind several features that take the EOS 5D Mark II to the next level. These include the 3.5mm diameter stereo mini jack for connecting a stereo microphone or external audio mixer to the camera, a built-in speaker for audio playback, an HDMI output jack for viewing both stills and video clips on an HDTV monitor, and the ability to record either 16:9 ratio, 1080p HD videos with sound, or 4:3 ratio, SD (VGA resolution, 640 x 480) videos with sound directly to UDMA or high speed CF cards.

The two video resolution choices are selected via menu on the camera's LCD, as are the desired Picture Style settings for creative control of the video image quality. Once the camera is set to Live View mode, pressing the Set button on the camera back activates the video recording function.

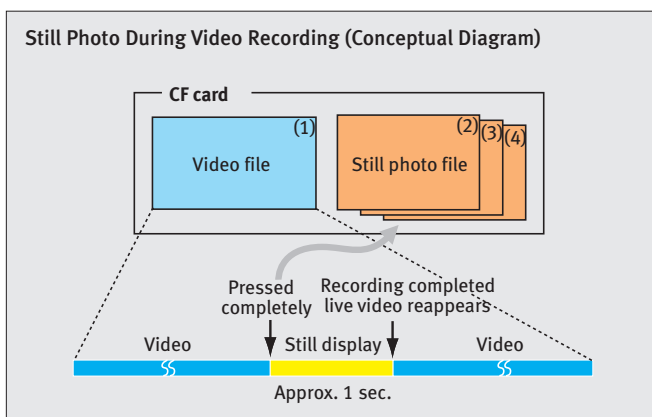

At any time during video recording, photographers can capture high-resolution still images with the press of the shutter button (or up to 3.9 fps burst rate). Still images taken during recording are always shot in Program AE mode, regardless of the Mode Dial settings in effect. ISO is also set automatically for still images during video recording, from 100 thru 6400, or up to ISO 12,800 when ISO expansion is activated in the Custom Function menus. During the time it takes to record the image as a separate file on the memory card, a freeze frame of the photo is displayed during playback, and sound recording is temporarily suspended.

If desired, the Live AF Function, with or without Face Detection, can also be activated during video recording mode by pressing the AF-ON button on the EOS 5D Mark II's back panel (there are some potential limitations to live autofocus during moving recording). Manual focusing and zooming of the attached lens is also possible during video recording, and recommended when using the camera's internal microphone to reduce the chances of recording AF motor noises.

In order to view 100% of the scene while recording in 16:9 ratio HD or 4:3 ratio SD, the camera automatically adjusts the LCD display to the proper aspect ratio with unused portions of the normal 3:2 aspect ratio still image area partially grayed out. The display can also be set to include exposure and time remaining indicators, as well as the movable focus frame area. In playback mode, a familiar tool bar allows you to jump from scene to scene, pause action, or proceed in slow motion. When connected to an HDTV via an optional HDMI cable, the camera automatically senses the resolution of the TV and provides the proper signal for the highest quality video playback possible.



Video Display (16:9)

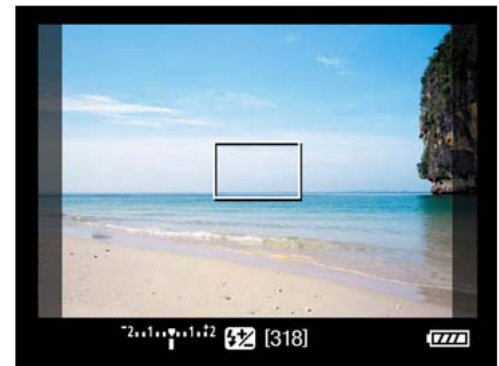

Video Display (4:3)

Since the camera records video using the popular “.mov” storage format, a wide variety of movie editing programs can be used to edit the video clips or combine clips into short videos. Canon includes its Movie Edit Task software, for Mac or Windows computers, to allow basic video editing at the computer. These clips can then be resaved on a CF card and played back on the camera monitor or fed out to an HDTV via an HDMI cable or provided audio video cable. That’s a great way to show off your video highlight or even slideshow portfolios of your favorite subjects.

Positioning **Thinking outside the box:** Many still photographers have never even used a camcorder or had video training. To them, the HD video recording mode on the EOS 5D Mark II might seem as odd a feature as adding Live View Function once did on a DSLR. (But once you’ve used Live View Function to shoot an otherwise impossible macro shot, or take photos remotely from a computer, you’ll understand its benefits.) So here are some scenarios where the video recording feature might help to increase a photographer’s sales or capture unforgettable moments:

Wedding photographers: Some couples can’t afford to hire both a professional photographer and a professional videographer, and when they can, both pros can’t always be in the same place at the same time. The EOS 5D Mark II can be used to capture an HD video of the bride throwing the bouquet (freezing the flowers in mid air in a still frame, of course!) and then continue to record HD action as bridesmaids and guests battle for control of the bouquet (or turn and run in the other direction!)

Photojournalists: The market for high-resolution video news footage and for expanded web video coverage of news events can increase the commercial possibilities for traditional still photographers at news or sporting events. This is especially true in situations where a photojournalist is already holding the EOS 5D Mark II over his head in Live View mode in order to get a view of the action. For some newspapers, the resolution provided by a single HD video frame might be more than adequate for printing if that scene captures the defining moment at an event, in which case the EOS 5D Mark II captures 30 frames per second!

Fashion and runway: The crush of photographers and videographers competing for every available inch of space at the end of a fashion runway may be a scene (and nightmare) of the past once the EOS 5D Mark II hits Fashion Week. That's because one camera will be able to do both jobs well and ease the camera crowd pressure. With a hand-held, image stabilized, wide angle to moderate telephoto zoom lens, the only thing a dedicated still shooter will have to remember is that videos don't record well when the camera is held in a vertical orientation. But with the incredible resolution captured by this camera in still mode, who will know you didn't shoot verticals?

Underwater photographers: First, digital photography expanded the number of shots possible during a photo dive from 36 exposures (on film) to hundreds on a memory card. Then came the relief of using the Live View Function instead of trying to squeeze a dive mask against the small viewfinder. Now it's set to revolutionize the underwater photography and video world with a camera that's small enough to fit in a moderately priced still camera housing, yet has the potential to capture both wide angle HD video clips and superior quality still photos. This is the kind of camera that works well under pressure!

Nature: You've hiked to the remotest corners of the Alaskan wilderness to capture Grizzly bears during the salmon run, bald eagles gathering in unprecedented numbers, or polar bears giving birth. You only had enough room in your backpack (and energy in your body) for one camera system during these once in a lifetime moments—and you chose the EOS 5D Mark II. Why limit yourself to selling the incredible still photos you captured to The National Geographic magazine when in the same building you can try to sell HD video footage for use on the National Geographic HDTV channel?

Law enforcement: Documenting a crime scene or capturing surveillance photos can be a challenging task, and you don't want to miss the evidence or any aspects of a crime in progress. In HD video recording mode, you won't miss a thing, and you can always capture a high-resolution still image for extreme enlargement when something catches your eye. Now, imagine placing the EOS 5D Mark II closer to the action and controlling it from an optional remote control or even a remote computer—and you're realize the benefits of its video recording prowess plus its silent still shooting mode.

Tech Info **Video resolution:** Capture Full HD videos (1920 x 1080 pixels) at 30 fps with mono sound (from camera) or stereo sound (from compatible external audio source). Captures standard SD videos (640 x 480 pixels) at 30 fps.

Video recording format: MOV using MPEG-4 compression (H.264).

Audio format: Sound is recorded as linear PCM without compression in mono (when recorded by monaural microphone located under camera nameplate) or in stereo (when using optional external stereo microphone). Sound levels and wind filter settings are adjusted automatically by the camera.

Recording time: The EOS 5D Mark II will record video up to 4GB per clip or a maximum continuous video capture time of 29 minutes and 59 seconds, whichever comes first. Depending on the level of detail in the scene, a 4GB memory card can record approximately 12 minutes of movies at Full HD resolution or approximately 24 minutes in standard definition.

Exposure: When shooting videos, the metering mode is set to a modified evaluative metering which uses the image sensor. Exposure is controlled using Program AE and allows exposure compensation and AE lock. ISO is automatically set by the camera (100 to 6400, expandable to 12,800), and video shutter speeds range from 1/30 to 1/125th (always set automatically by the camera).

Picture Style: Video are recorded using the Picture Style set for Live View Function still shooting (black & white video recording is possible). Picture Style sharpness, color saturation, and other parameters will be reflected in the video footage.

Input jacks: 3.5mm external stereo microphone terminal

Output jacks: HDMI output terminal (cable sold separately) and Audio/single-pin Video OUT terminal (cable included).

Playback controls: Includes play, pause, stop, single frame advance, slow motion playback in forward and reverse, jump to beginning or end of clip, and audio output level. In thumbnail review mode, videos show perforation graphic to left side to differentiate them from still photos.



FULL HD
1080



New Video Shooting Capability

Still photographers who also need to capture motion picture video will find the video recording capabilities of the EOS 5D Mark II highly useful, often eliminating the need to carry a separate camcorder. The EOS 5D Mark II can shoot video at Full HD (High Definition) at 1920 x 1080 pixels or SD (Standard Definition) at 640 x 480 pixels. The frame rate is 30 fps.

To begin video shooting, the user simply presses the SET button while the camera is in Live View mode. Pressing SET again ends recording. The maximum file size of individual video clips is 4GB. This works out to approximately 12 minutes of footage when shooting in HD, and 24 minutes shooting SD. There is no real delay before being able to start the next new video clip, and the only limit to the number of clips you can shoot is the size of your memory card. Videos are recorded as MOV files (with MPEG-4 compression), and the sound is recorded using uncompressed linear PCM (pulse code modulation).

The Picture Style selected for the Live View mode is used for video recording. Thus, adjustments to a Picture style — such as sharpness, color saturation, etc. — will be reflected in the captured video footage.

Focus is performed prior to the start of video recording. As with still shooting, the user

can focus manually or use one of three AF modes. Focus can be reacquired in the midst of video shooting using the AF-ON button. Program AE is used for exposure control with all video recording. The image sensor is used for metering, and exposure is calculated in real time using an evaluative algorithm.

A built-in microphone below the camera nameplate records monaural sound. Stereo recording is possible with an external stereo microphone connected to the camera's mic input connector (a standard 3.5mm stereo jack). Audio levels are automatically adjusted whether recording with the built-in or an external microphone.

Still photos can be captured at any time during video recording simply by pressing the shutter release button. The photo is captured at the currently active still image quality settings. Video recording is momentarily interrupted while a still photo is being captured; the Live View Function returns and video recording automatically resumes as soon as the still capture is completed.

Video can be played back on the EOS 5D Mark II LCD monitor with sound reproduced via a built-in speaker located to the right of the viewfinder eyepiece. Playback options include standard and slow motion replay (with variable speed) and various still-frame capabilities.



Video Playback Screen



Advanced Sensor Designs

EOS 5D Mark II's new 21.1-megapixel full-frame CMOS sensor: The advanced single-plate CMOS sensor in the EOS 5D Mark II achieves the highest performance of any sensor in the Canon DSLR lineup. It shares many traits with the CMOS sensor found in the flagship

EOS-1Ds Mark III, including its 36mm x 24mm (35mm format) size, approximately 21.1 effective megapixels with 6.4µm pixel pitch, a 4-channel data readout, and low-pass filter design. However, this second-generation sensor offers increased sensitivity and improved noise reduction circuitry that enables standard ISO's ranging from 100 to 6400 and expanded ISO ranges from 50 to 25,600.

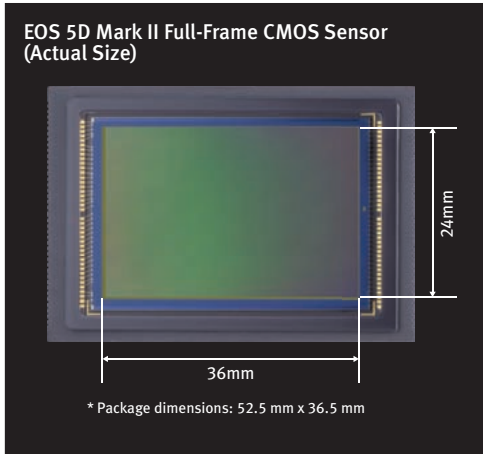

The EOS 5D Mark II's sensor is designed and manufactured entirely by Canon using its state-of-the-art CMOS semiconductor fabrication and microlens-forming process. It includes a protective, double low-pass filter design that separates the subject image into horizontal and vertical directions, a phase plate, and an infrared-absorption glass. (The front side of the first low pass filter also includes a fluorine coating to help reduce dust adhesion and a dichroic mirror vapor deposition on the rear surface to reflect infrared rays.)

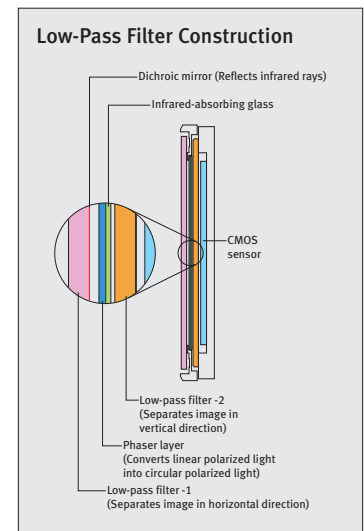

Compared to the original EOS 5D, the gap between the on-chip microlenses on the EOS 5D Mark II has been narrowed while the photodiode area ratio (photodiode area divided by the pixel size) has been increased. The distance between the microlens and photodiode has been further reduced to improve light gathering efficiency, and new color filter materials have been added to increase light transmission while retaining accurate color reproduction. These optical

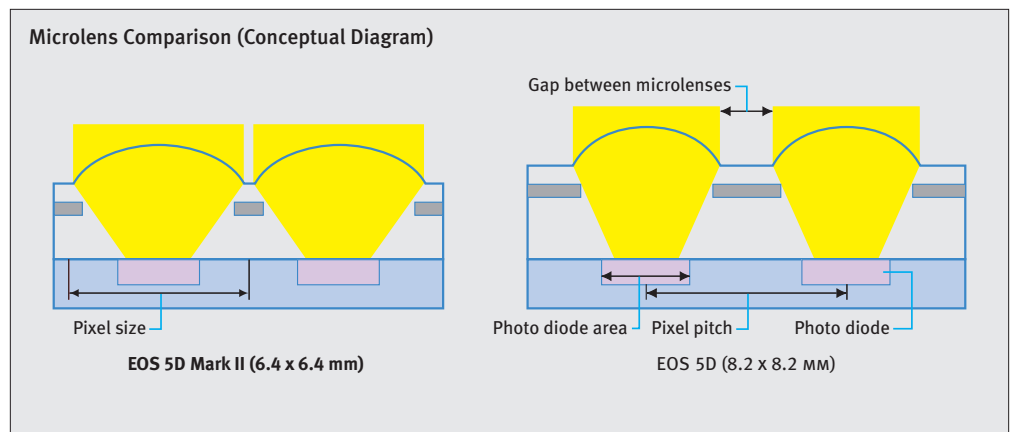

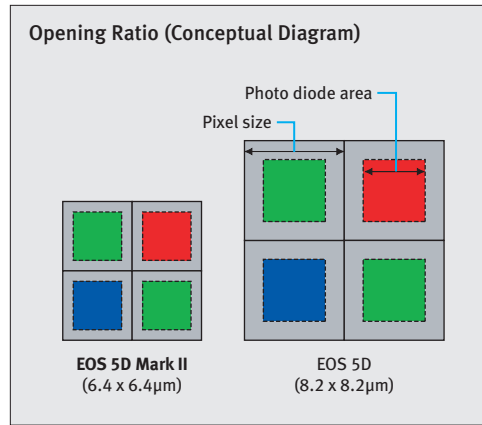

advances and technology improvements to the sensor, plus countermeasures that help suppress noise from other camera circuits, are responsible for the sensor’s high signal to noise ratio, enabling higher ISO speeds and improved dynamic range at low ISOs. Those are impressive sensor improvements, considering that the original EOS 5D had larger 8.2µm pixels compared to 6.4µm pixels on the EOS 5D Mark II, and that pixel noise usually increases as size decreases.

Next, an optimized output amp with high-speed reading capability that is approximately 2.2 times faster than on the EOS 5D enables a faster burst mode of 3.9 fps (compared to 3.0 fps on the EOS 5D’s lower resolution 12.8-megapixel full-frame sensor) and makes it possible to readout a 30 fps HD video signal without overheating the sensor. The full-frame, 35mm “film” size of the EOS 5D Mark II’s sensor also maximizes the field of view of Canon’s EF lenses without adding the 1.6x lens crop factor found in APS-C sensor-based DSLRs. This is especially important when shooting with fisheye, ultra-wide, and wide-angle lenses, as it maintains the same field of view as those lenses have when mounted on conventional 35mm SLRs. It also improves depth-of-field control with normal lenses compared to APS-C sensor cameras, with dramatic DOF control when shooting HD video.

EOS 50D’s newly developed, 15.1-megapixel APS-C sized CMOS sensor: Even though the new EOS 50D doesn’t have the full-frame sensor of the EOS 5D Mark II, it benefits from numerous advances in sensor technology. Offering the highest performance to date of any APS-C sized imaging sensor, the new Canon-manufactured, 22.3mm x 14.9mm CMOS sensor found in the EOS 50D helps maintain a heritage of innovation and superior image quality found in all of its predecessors. It contains approximately 15.1 effective megapixels, gapless microlenses, improved

noise reduction, and a Live View silent shooting mode with electronic 1st curtain shutter. As with the EOS 40D, the sensor size creates a lens crop factor of 1.6x for all Canon EF and EF-S lenses.

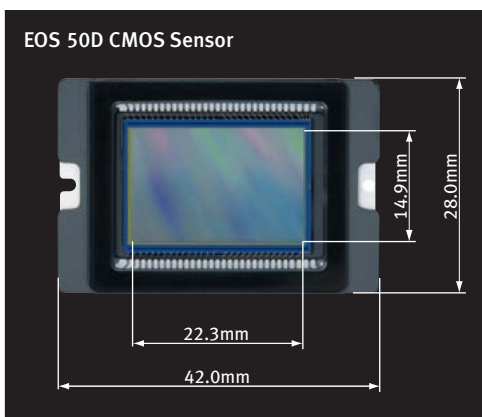

Sensor Comparison Chart

Specification	EOS 50D	EOS 40D
Effective pixels	Approx. 15.10 million (4752 x 3168)	Approx. 10.10 million (3904 x 2598)
Total pixels	Approx. 15.50 million (4848 x 3204)	Approx. 10.50 million (3996 x 2620)
Effective sensor size [mm]	22.3 x 14.9	22.2 x 14.8
Pixel size [µm]	4.7	5.7
Color filter	RGB primary color filter	
Aspect ratio	3:2	

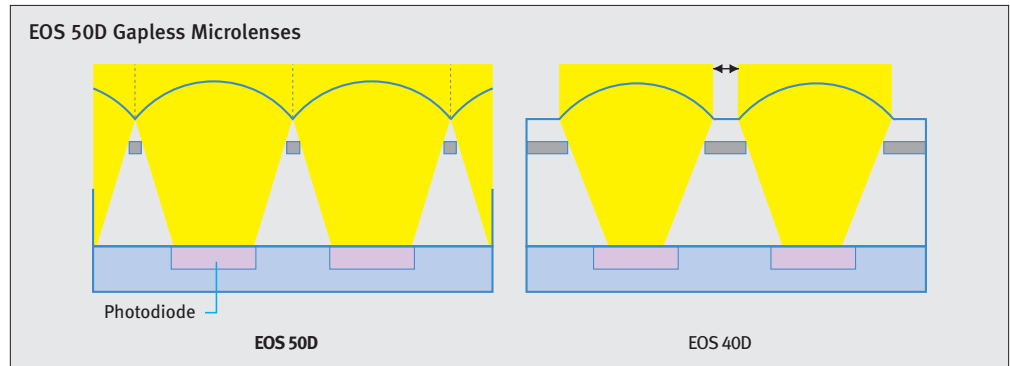

Several optical and electronic technology advancements debut in the EOS 50D’s CMOS sensor. For starters, a new micro manufacturing process was used in the CMOS semiconductor production phase to increase the light-sensitive photodiode area. Above the photodiode, gapless microlenses improve the light-gathering efficiency of the smaller 4.7µm pixels and help achieve high ISO speeds (standard range from ISO 100 to 3200, with expanded 6400 or 12,800 ISO settings possible) plus lower noise images than on the EOS 40D.

Next, improved 4-channel data reading from each line on the sensor paired with a new high-speed, low-voltage amp increases the signal speed by about 1.5x over the EOS 40D’s sensor, helping to maintain a fast 6.3 fps burst rate despite the higher amounts of data coming from the sensor’s 15.1 megapixels. Power consumption is also reduced.

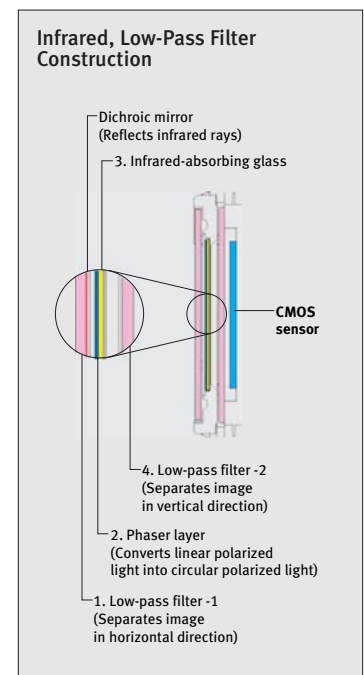

In front of the CMOS imaging surface and micro-mirror array is a protective infrared and low-pass filter array that is similar in design to the one found on the EOS 40D. However, as on the EOS 5D Mark II, Canon has added a dust-repelling fluorine coating to the front surface of the first low pass filter and moved the infrared blocking, dichroic coating to the back side of that filter.

DIGIC 4 and 14-Bit A/D Conversion

Both new EOS DSLRs rely on the incredible speed, advanced image-processing capabilities, and lower power consumption provided by Canon’s DIGIC 4 Image Processor. The major advances and features it provides over the DIGIC III Image Processor in the EOS 40D or older DIGIC II Image Processor found in the EOS 5D include:

- 1) Low noise image development, allowing for better noise reduction at all ISOs and 2 stops higher normal ISO speed in the EOS 5D Mark II.

- 2) Higher speed image processing (1.3x faster than on the DIGIC III) that also provides superb tonal gradations during the 14-bit A/D conversion of RAW data (16,384 per channel of RGB data compared to 4,096 per channel in competitive 12-bit processors). This results in improved highlight and shadow details, extended dynamic range, and more accurate, saturated colors that maintain fine details.
- 3) Improved high ISO Noise Reduction, corresponding to higher image quality and allowing the cameras to maintain their fast maximum shooting speeds and burst rates with two out of three noise reduction settings.
- 4) Expands the functions and speed of the Auto Lighting Optimizer feature.
- 5) Incorporates processing algorithms for Peripheral Illumination Correction.
- 6) Enables Face Detection and optimized metering of up to 35 faces in Live Face Detection AF shooting mode.
- 7) Controls the HDMI signal output and HDTV resolution matching function.
- 8) Adds high speed UDMA Mode 6 (CF card) read and writing speed compatibility.
- 9) Controls the VGA (920,000-dot) video signal to the LCD monitor display in all modes.
- 10) Allows cameras to capture images in sRAW1 and sRAW2 reduced-resolution sizes.

EOS 5D Mark II (only) DIGIC 4 Image Processor improvements:

- 1) Enables 1080p Full HD video recording mode with sound, standard definition (SD) video recording with sound, and video playback with sound
- 2) In Highlight Tone Priority mode, the highlight the gradation is expanded by about 1 stop over the EOS 5D. (EOS 50D also benefits from Highlight Tone Priority feature.)
- 3) Processes the signals from the EOS 5D Mark II's ambient light detector and uses it to control LCD brightness as well as adjust white balance shifts during video recording.

As a result of the advanced sensor designs and inclusion of the DIGIC 4 Image Processor, both new EOS DSLR models are faster, and capture images with noticeably improved image quality—especially in resolution and low noise at high ISOs. The DIGIC 4 Image Processor also provides several other enhancements and new features.

Image Recording and Processing

RAW, sRAW and RAW+JPEG

To control image resolution and file size or to preserve RAW data, both cameras offer six choices for JPEG capture: Large (full) resolution in with fine quality or normal quality compression settings; Medium resolution (8 megapixels on EOS 50D, 16 megapixels on EOS 5D Mark II) with either fine or normal quality compression, and Small resolution (3.7 megapixels on EOS 50D, 5.2 megapixels on EOS 5D Mark II) with fine and normal compression settings.

In addition to these, there are three RAW file types that can be combined with any of the six JPEG settings in the RAW+JPEG mode for a total of 27 image quality-recording modes on each camera. The sRAW1 format captures 7.1 megapixels on the EOS 50D, 10 megapixels on the EOS 5D Mark II. Next, sRAW2 captures 3.8 megapixels on the EOS 50D and 5.2 megapixels on the EOS 5D Mark II.

EOS 50D Image Recording Specifications

Image-recording Quality	Image File Size [Approx. MB]	Possible Shots [Approx.]	Maximum Burst [Approx.]		
			High-speed	Low-speed	
JPEG	L	5.0	370	60 (90)	370 (370) F
	L	2.5	740	150 (740) F	740 (740) F
	M	3.0	620	110 (620) F	620 (620) F
	M	1.6	1190	390 (1190) F	1190 (1190) F
	S	1.7	1090	330 (1090) F	1090 (1090) F
	S	0.9	2040	1050 (2040) F	2040 (2040) F
RAW	20.2	91	16 (16)	20 (29)	
RAW+L	20.2+5.0	72	10 (10)	15 (18)	
RAW+L	20.2+2.5	80		16 (21)	
RAW+M	20.2+3.0	79		17 (24)	
RAW+M	20.2+1.6	84		18 (24)	
RAW+S	20.2+1.7	83		18 (24)	
RAW+S	20.2+0.9	87		18 (24)	
S RAW 1	12.6	140	16 (16)	32 (82)	
S RAW 1+L	12.6+5.0	100	10 (10)	21 (27)	
S RAW 1+L	12.6+2.5	120		23 (27)	
S RAW 1+M	12.6+3.0	110		25 (27)	
S RAW 1+M	12.6+1.6	130		25 (27)	
S RAW 1+S	12.6+1.7	120		27 (27)	
S RAW 1+S	12.6+0.9	130		27 (27)	
S RAW 2	9.2	200	19 (19)	51 (200) F	
S RAW 2+L	9.2+5.0	120	11 (11)	25 (32)	
S RAW 2+L	9.2+2.5	150		30 (32)	
S RAW 2+M	9.2+3.0	150		32 (32)	
S RAW 2+M	9.2+1.6	170		32 (32)	
S RAW 2+S	9.2+1.7	160		32 (32)	
S RAW 2+S	9.2+0.9	180		32 (32)	

The number of possible shots and maximum burst apply to a 2GB CF card based on Canon's testing standards. The image file size, number of possible shots, and maximum burst will vary depending on the shooting conditions (subject, memory card brand, ISO speed, Picture Style, etc.). Figures in parentheses apply to an UDMA 2GB CF card based on Canon's testing standards. For the figures that have "F", shooting is possible until the card becomes full.

EOS 5D Mark II Image Recording Specifications

Image-recording Quality	Pixels [Approx.MB]	File Size [Approx. MB/Shot]	Possible Shots [Approx.]	Maximum Burst [Approx.]	Printing Size [Inch]	
JPEG	L1	21.00 (5616 x 3744)	6.1	310	78 (310*)	16.5x23.4 or larger
	L2		3.0	610	610* (610*)	
	M1	11.10 (4080 x 2720)	3.6	510	330 (510*)	Around 11.7x16.5
	M2		1.9	990	990* (990*)	
	S1	5.20 (2784 x 1856)	2.1	910	910* (910*)	Around 8.3x11.7
	S2		1.0	1680	1680* (1680*)	
RAW	21.00 (5616 x 3744)	25.8	72	13 (14)	16.5x23.4 or larger	
S RAW 1	10.00 (3861 x 2574)	14.8	120	15 (15)	Around 11.7x16.5	
S RAW 2	5.20 (2784 x 1856)	10.8	170	20 (20)	Around 8.3x11.7	
RAW+L1	21.00 (5616 x 3744)	25.8 + 6.1	57	8 (8)	RAW: 16.5x23.4 or larger JPEG: 16.5x23.4 or larger	
RAW+L2	21.00 (5616 x 3744)	25.8 + 3.0	64	8 (8)		
RAW+M1	11.10 (4080 x 2720)	25.8 + 3.6	62	8 (8)	RAW: 16.5x23.4 or larger JPEG: Around 11.7x16.5	
RAW+M2	11.10 (4080 x 2720)	25.8 + 1.9	67	8 (8)		
RAW+S1	5.20 (2784 x 1856)	25.8 + 2.1	66	8 (8)	RAW: 16.5x23.4 or larger JPEG: Around 8.3x11.7	
RAW+S2	5.20 (2784 x 1856)	25.8 + 1.0	69	8 (8)		
S RAW 1+L1	10.00 (3861 x 2574)	14.8 + 6.1	89	8 (8)	sRAW1: Around 11.7x16.5 JPEG: 16.5x23.4 or larger	
S RAW 1+L2	10.00 (3861 x 2574)	14.8 + 3.0	100	8 (8)		
S RAW 1+M1	10.00 (3861 x 2574)	14.8 + 3.6	100	8 (8)	sRAW1: Around 11.7x16.5 JPEG: Around 11.7x16.5	
S RAW 1+M2	11.10 (4080 x 2720)	14.8 + 1.9	110	8 (8)		
S RAW 1+S1	5.20 (2784 x 1856)	14.8 + 2.1	110	8 (8)	sRAW1: Around 11.7x16.5 JPEG: Around 8.3x11.7	
S RAW 1+S2	5.20 (2784 x 1856)	14.8 + 1.0	110	8 (8)		
S RAW 2+L1	5.20 (2784 x 1856)	10.8 + 6.1	110	8 (8)	sRAW1: Around 8.3x11.7 JPEG: 16.5x23.4 or larger	
S RAW 2+L2	5.20 (2784 x 1856)	10.8 + 3.0	130	8 (8)		
S RAW 2+M1	5.20 (2784 x 1856)	10.8 + 3.6	130	8 (8)	sRAW1: Around 8.3x11.7 JPEG: Around 11.7x16.5	
S RAW 2+M2	11.10 (4080 x 2720)	10.8 + 1.9	140	8 (8)		
S RAW 2+S1	5.20 (2784 x 1856)	10.8 + 2.1	140	8 (8)	sRAW1: Around 8.3x11.7 JPEG: Around 8.3x11.7	
S RAW 2+S2	5.20 (2784 x 1856)	10.8 + 1.0	150	8 (8)		

The number of possible shots and maximum burst are based on Canon's testing standards and a 2GB CF card. Under Maximum burst, the number in parentheses is the maximum burst with a UDMA-compatible 2GB CF card used in Canon's testing standards. JPEG L1, ISO 100, Picture Style: Standard, Custom Function: Default settings. The actual file size, number of possible shots, and maximum burst will vary depending on the subject, memory card brand, image-recording quality, ISO speed, Picture Style, Custom Function settings, etc. Shooting is possible until the card becomes full.

Additional sRAW formats with lower resolution allow you to shoot images for use on the web, or increase the number of RAW photos you can fit on a memory card, without sacrificing the post processing advantages found in Canon's provided Digital Photo Professional software, such as white balance adjustment, exposure compensation, Picture Style settings, and lens distortion corrections.

For added convenience and organization, both cameras also allow you to create new folders on CF cards and to freely select which folder upcoming images will be stored in. By selecting the menu protect function, individual images can be protected from accidental erasure, or you can checkmark multiple images for deletion and remove them all at once. When either the EOS 50D or EOS 5D Mark II is used with the appropriate dedicated optional wireless file transmitter, image recording can be set to simultaneously record images to the CF card or external USB drives attached to the transmitter.

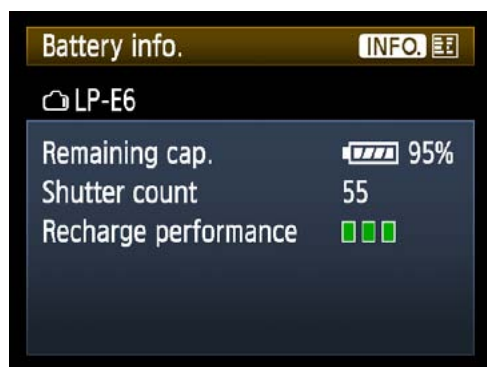

Battery Information



Battery-use History

Intelligent lithium-ion battery on EOS 5D Mark II

While the EOS 50D continues to use the same 1390mAh BP-511A Lithium-ion battery as its predecessor, the EOS 5D Mark II utilizes a higher capacity 1800mAh lithium-ion Battery Pack LP-E6 with new capabilities. The battery can now communicate the remaining capacity in one of six levels via the battery-check icon and in 1% increments using the Battery Info menu. The number of shutter releases since the battery was last recharged is also displayed, and stored in the battery in case it is removed. Recharging the battery resets the shutter count. Battery recharge performance is also shown in up to three levels, giving a better indication of when it might be time to replace the battery altogether.

The unique serial number contained within each Battery Pack LP-E6 allows you to register multiple batteries within the camera and display information about those batteries, including the last time each was used and its most recent level of charge at that time. More importantly, it can help you select a replacement battery based on its charge capacity so that you don't install a nearly depleted battery at the wrong time.

Image Enhancement High ISO Noise Reduction

High ISO noise reduction can be set to improve image quality at high ISO settings on both cameras. While some noise reduction is applied automatically even to images taken at low ISOs, turning on this function can further reduce noise in low and moderately low ISO images, especially those taken in very hot environments where heat tends to increase camera noise.

On both the EOS 50D and the EOS 5D Mark II, you access High ISO noise controls via (C.Fn II-2). There are four settings: Standard, Low, Strong and Off (the default is Standard).

On either camera, the maximum burst rate should remain the same (3.9 fps on the EOS 5D Mark II and 6.3 fps on the EOS 50D) when the High ISO setting is set to either Standard or Low. However, burst speed will slow down slightly when the Strong setting is used, due to the extensive level of in-camera processing required.

Peripheral Illumination Correction

The DIGIC 4 Image Processor found in both cameras powers an image processing tool formerly found only in Canon's Digital Photo Professional (DPP) software: Peripheral Illumination Correction (PIC). When it is activated via the menu, JPEG images are automatically corrected for light falloff towards the edge of the image. This problem isn't always noticeable prior to correction, and varies by type of lens and aperture used, as well as the distance a lens' focus is set to. Both cameras are capable of storing the required lens correction data for up to 40 Canon lenses. When shipped, the data for 26 lenses (including the kit lens) is loaded into the camera. Up to 14 additional lenses can be registered in the camera, and if more are needed, you can delete unused lens data via the EOS Utility software included with the camera. If a lens is supported, a notice "Correction Data Available" will appear in the menu control.

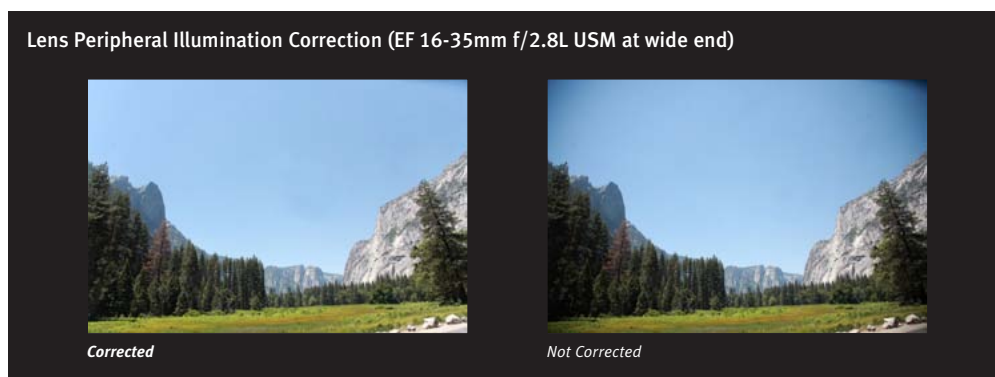

EF16-35mm f/2.8L II USM	EF28-105mm f/3.5-4.5 II USM	EF28mm f/2.8
EF17-40mm f/4L USM	EF28-105mm f/4-5.6 USM	EF35mm f/1.4L USM
EF20-35mm f/3.5-4.5 USM	EF28-135mm f/3.5-5.6 IS USM	EF35mm f/2
EF24-70mm f/2.8L USM	EF28-200mm f/3.5-5.6 USM	EF50mm f/1.2L USM
EF24-85mm f/3.5-4.5 USM	EF28-300mm f/3.5-5.6L IS USM	EF50mm f/1.4 USM
EF24-105mm f/4L IS USM	EF14mm f/2.8L II USM	EF50mm f/1.8 II
EF28-90mm f/4-5.6	EF20mm f/2.8 USM	EF85mm f/1.2L II USM
EF28-90mm f/4-5.6 II	EF24mm f/1.4L USM	EF85mm f/1.8 USM
EF28-90mm f/4-5.6 III	EF24mm f/2.8	
EF28-105mm f/3.5-4.5 USM	EF28mm f/1.8 USM	

The EF28-90mm f/4-5.6/II/III and EF28-105mm f/3.5-4.5/II have the same optics so they are all represented (displayed) as "EF28-90mm f/4-5.6" and "EF28-105mm f/3.5-4.5" respectively.

When PIC is enabled and data is contained within the camera for the lens in use, the right amount of correction is applied automatically to JPEG images at all apertures and focal length settings. This correction is of the same nature as the correction available under the Lens Aberration Correction control panel in the DPP software. However, camera-applied vignetting correction isn't as powerful (roughly 70% of the correction possible in DPP).

With RAW files, images are automatically tagged with the correction needed, if a compatible lens is used and PIC is turned on. Processing these images in Canon's DPP software will allow automated vignetting correction, tailored specifically to that lens. If shooting in RAW+JPEG mode, PIC will be applied to the JPEG files, allowing you to increase or decrease the correction later on the RAW file using the DPP software.

Please note that if RAW files are processed using a third-party software application, in most cases any such in-camera tags are ignored, and you'll need to use the software's own tools (if available) manually for any such correction.

Auto Lighting Optimizer

Another powerful image correction feature found in both new DSLRs is the Auto Lighting Optimizer (ALO). This feature can be used to greatly improve the impact and quality of underexposed, muddy JPEG images, including backlit portraits that accidentally underexposed the subject, and portraits where the subject was slightly out of range of the flash (the camera's ability to detect faces plays a part in this correction). Flat, low contrast scenes can also be given extra snap when using this function. More sophisticated and more powerful than the Auto Brightness and Contrast Correction found in the EOS 40D's Basic Zone Mode, ALO can be accessed via the custom menu (C.Fn II -4), and has three settings in addition to disabled: Standard, Low, and Strong. In addition, ALO can now be activated in RAW and RAW+JPEG instead of being limited to JPEG.

Highlight Tone Priority

Found previously in the EOS 40D, but completely new to the full-frame EOS 5D Mark II, Highlight Tone Priority greatly improves the image quality of high contrast and high key scenes. It effectively increases dynamic range and detail in highlight areas, minimizing blown out details in a white fabric (such as a wedding dress) or high contrast scenes such as snow-covered landscapes. Only brightness values between 18% middle gray and the maximum-recorded brightness are affected, while shadow and midtone areas of a scene remain untouched. In both the EOS 50D and the EOS 5D Mark II, a new Highlight Tone Priority status indicator (D+) now appears on the 3.0-inch LCD and in the viewfinder. ISO range is a bit more limited when Highlight Tone Priority is active: when used in the EOS 50D, the selectable ISO range decreases to ISO 200–3200, and on the EOS 5D Mark II (C.Fn II -3), the ISO range is limited to ISO 200–6400.

High resolution, 3.0-inch Clear View LCD

The new 3.0-inch Clear View LCD found on both the EOS 50D and EOS 5D Mark II is a significant improvement over the 3.0-inch on the EOS 40D and a vast improvement over the EOS 5D's 2.5-inch LCD. It now features 920,000-dot resolution, providing nearly four times the detail and sharpness of the EOS 40D and EOS 5D screens, and matching the VGA resolution of the SD movie-recording mode on the EOS 5D. It also features improved color accuracy and a more linear color reproduction that reduces changes in hue typically found in highlight areas. Both sides of the LCD's protective cover feature an anti-reflective coating that reduces reflections on the LCD cover-glass, making it easier to view menus and images in bright sunlight. A third, water-repellent coating increases resistance to smudges and moisture.

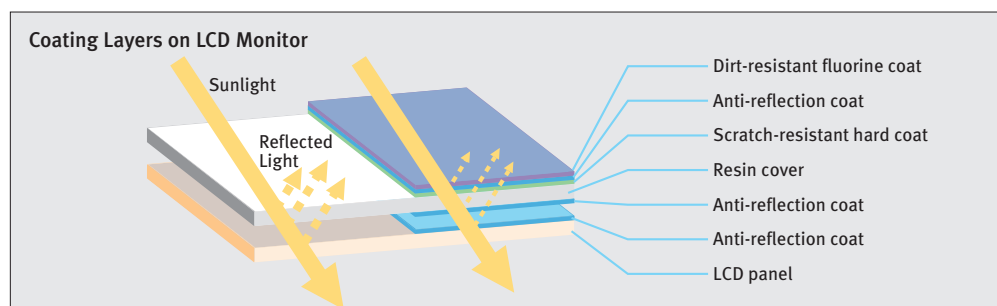

In playback mode, the high screen resolution makes it possible to see extensive detail even when displaying nine thumbnail images, and allows you to check for closed eyes without zooming in on the image.

The LCD covers 100% of the sensor capture area and is viewable from a super-wide 170° angle in either vertical or horizontal directions. This wide view angle expands the usefulness of the LCD in Live View mode, allowing you to accurately compose images while holding the camera at arms length or over your head. It also makes it possible to show off captured still images (or movies on the EOS 5D Mark II) to a group of viewers standing around the camera. In addition, when using the movie recording function on the EOS 5D Mark II, the LCD automatically displays an image with the correct 16:9 or 4:3 aspect ratio, with unused portions of the scene partially grayed out.



Video Display (16:9)



Video Display (4:3)

Another “first” for EOS Digital SLRs: a light sensor on the EOS 5D Mark II that monitors ambient lighting controls the LCD brightness. This auto control can be set to Dark, Standard, or Bright, or you can manually set the LCD to one of seven brightness levels. You can also choose between two grid displays or set the camera to simulate exposure accuracy while in Live View mode.

Live View Shooting with AF

In the EOS 40D, only Quick Mode autofocus during Live View Function was available, and Live View Function itself wasn't even possible on the EOS 5D. Now, for both the EOS 50D and EOS 5D Mark II, the Live View mode can be turned on in any normal exposure mode (including program, aperture, shutter, manual, and even A-DEP) by pressing the Live View mode activation button located to the left of the viewfinder. Image composition and viewing in bright light has also been dramatically improved with the addition of the new 3.0-inch 920,000-dot Clear View LCD with anti-reflective coatings and super-wide 170° viewing angle. This monitor also delivers a more accurate exposure simulation when that setting is enabled via the custom function menu on either camera. In addition, there are now two grid displays available to assist in scene composition and alignment.

As on the EOS 40D, the Silent Shutter mode, which utilizes the sensor's 1st curtain electronic shutter, helps to minimize noise during exposure, reduces shutter-cocking noise, and can be a very useful feature when trying to get close-up wildlife shots without spooking the subject. In combination with an optional remote trigger or when controlling the camera using supplied software on a remote computer, the silent shutter mode can greatly enhance the value of either camera for use in law enforcement or surveillance photography. Mode 1 in the Silent Shooting menu quiets down the camera's shutter noise when in Live View mode, and allows either single-frame or continuous shooting up to the camera's fastest advance speed. Mode 2 is virtually silent, and delays re-cocking the 2nd shutter curtain until you remove your finger from the shutter button.

There are now three types of autofocus for use in Live View mode compared to the EOS 40D's single AF (and no Live View AF mode at all on the full-frame EOS-1Ds Mark III).

- Quick Mode AF is useful when you are holding the camera and you want to achieve focus quickly. It's activated by pressing the AF-ON button, and causes the Live View Function to black out momentarily while the reflex mirror flips down and the camera's 9-point phase detection autofocus engine locks onto the subject.
- Live AF mode uses Contrast Detection from the actual imaging sensor and is slightly slower and less sensitive in low light but can be used without Live View Function black-out. In this mode, the AF mode zone box can be moved around to an area covering approximately 61% of the scene and centered on the subject of interest, allowing precision focus for macro subjects and other off-center subjects. Live AF mode is also possible during video recording with the EOS 5D Mark II; however, focusing manually is an easier, quieter, and more precise technique.
- Face Detection Live AF utilizes the power of the DIGIC 4 Image Processor to detect up to 35 faces in a scene. After analysis, a border box appears around the closest, or in

some cases, the largest face found in the scene and the camera focuses on that face (metering and color balance is also optimized to produce a more accurate facial tone based on the face in the box). The multi-controller then allows you to move the box to another face as desired, after which the AF and metering system will reset for that face.

E-TTL Flash photography is possible in normal Live View mode, but not when the Silent shutter mode is activated. Otherwise, when the shutter is pressed to capture the image when using the flash, the LCD blacks out as the mirror flips down and pre-flash exposure data is registered in the camera prior to exposure. The time delay is similar in length to that caused by pressing the AF Button in Live View mode. Flash photography is also supported when the EOS 5D Mark II is set to Live View Function, but it is disabled in HD video recording mode.

Precise 9-point AF Systems

The AF systems on both the EOS 50D and EOS 5D Mark II are very similar to the systems on the models they replace, with the same improvements appearing in both new cameras. Among these are faster AF data processing made possible by the DIGIC 4 Image Processor, improved AF precision, and AF Microadjustment for individual lenses.

The EOS 50D features 9 cross-type AF points arranged in a diamond pattern, with all sensitive to both horizontal and vertical details when using $f/5.6$ or brighter EF and EF-S lenses. This sensitivity achieves faster, more precise focusing with hard-to-focus subjects, and enables high-speed (6.3fps) continuous shooting in the AI SERVO AF mode while tracking a subject.

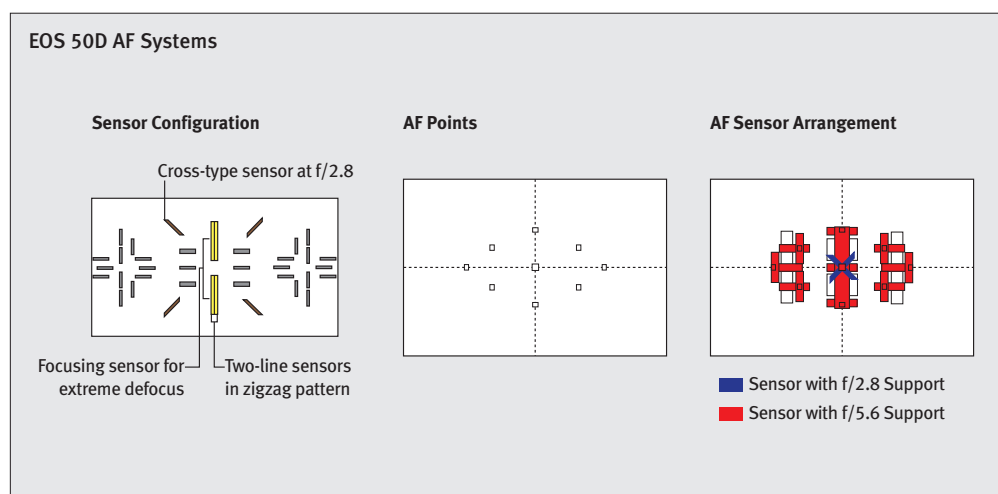

When using an $f/2.8$ or brighter maximum aperture lens, the central AF point offers enhanced cross-type sensitivity and faster detection of subjects in extreme defocus. This is achieved by adding diagonal sensors and a 2-line, zigzag configuration to the existing $f/5.6$ sensor already positioned in the center of the diamond.

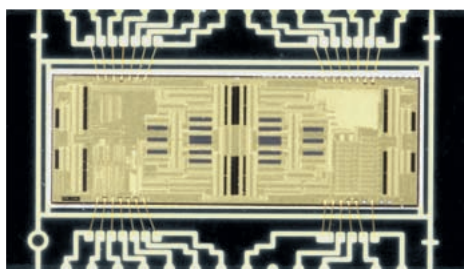
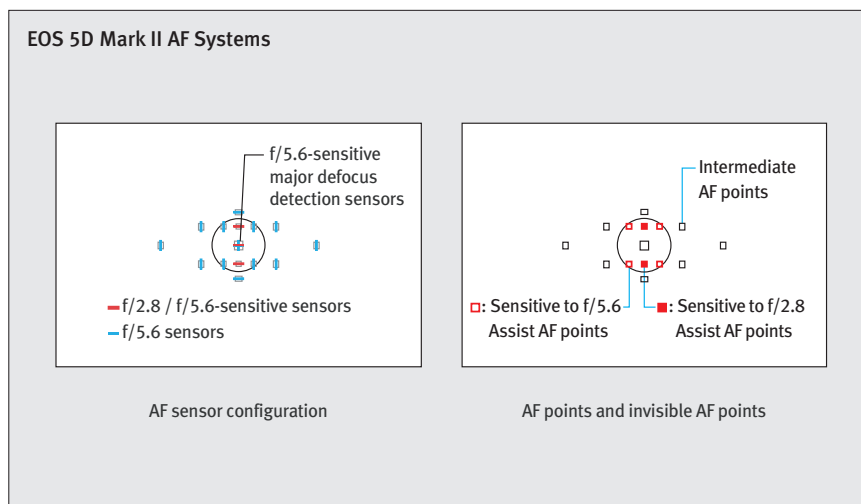

AF Sensor

The AF system on the EOS 5D Mark II includes 9 visible AF points and six invisible assist points, for a total 15 points concentrated toward the center. The outer points on the extreme left and right are actually located at the same positions as the corresponding points in the EOS-1Ds Mark III, giving the camera a wide field for detecting moving subjects crossing the scene or improved ability to focus on off-center subjects. While only 9 AF points are visible through the viewfinder, all can be revealed

using ZoomBrowser or ImageBrowser software. Among the six Assist AF points, the top and bottom points at the center are vertical-line sensitive with lenses featuring $f/2.8$ or brighter maximum apertures, while all other points are sensitive at $f/5.6$ or brighter. Focusing is started using the $f/5.6$, horizontal line-sensitive central sensors with individual pixels arranged in a zigzag pattern for improved extreme defocus detection. When focusing is nearly achieved (and when using an $f/2.8$ or brighter lens) focusing is handed off to the $f/2.8$ sensitive vertical line sensors.

The purpose of the supplemental points is to enhance the camera's subject tracking performance by filling in the gaps between the highly sensitive central AF point and the 8 adjacent linear sensors.

As on the EOS 50D, the EOS 5D Mark II's AF system is sensitive to light levels as low as EV -0.5, and capable of locking on to a moving subject and tracking it across the diamond-shaped AF area. Improved precision over previous AF systems stems from each camera's ability to adjust for different light sources while calculating focusing distance. Here's how it works: during Phase Detection AF, the AF engine rapidly measures the density of horizontal and vertical details in a scene and the camera processor uses this data to determine where the sharpest edges and details are located. When found, the AF is locked on target. But under fluorescent lighting and some other artificial lighting sources, a rapid, imperceptible flickering of the light occurs along with sudden color temperature shifts. These tend to throw off the density measurements and therefore the accuracy of the AF calculations. In both the EOS 50D and EOS 5D Mark II, the type of lighting is taken into effect, and readings are averaged and processed with the help of the super-fast DIGIC 4 Image Processor. The result is improved AF accuracy and speed when shooting under lighting conditions that could fool the AF systems found on earlier Canon and competitive models alike.

Improved Viewfinder Experience

The optical viewfinders on both cameras has been improved slightly, although the EOS 5D Mark II boasts the majority of changes. Its newly-developed pentaprism viewfinder now features 98% coverage compared to 96% on the EOS 5D, a clearer and crisper image, and a more comfortable 21mm eye point relief (compared to 20mm on the 5D). In addition, the Data Display in both viewfinders now includes a battery check indicator, an ISO speed number, a “D+” indicator when Highlight Tone Priority is activated, and a “B/W” symbol appears when the camera is set to black and white mode.

Rugged Construction

Both cameras share nearly all of the same internal and external body construction features found in their predecessors. These include rugged magnesium alloy main covers on the top, front, and rear (with the grip integrated into the front cover), for light weight and high strength. The stainless steel chassis is solidly fixed to the mirror box, which is made of engineering plastic to prevent any change in the flange focal distance when using heavy lenses. Extra care has been taken in the selection of moving parts in order to reduce the chance for microscopic particles that would cause dust spots on the sensor. The left side, which includes connectors such as the HDMI and audio video out terminals, is also made of engineering plastic with excellent electromagnetic shielding properties. Tight attached, weather-resistant rubber flaps cover these connectors.



EOS 5D Mark II Magnesium Alloy Body



EOS 5D Magnesium Alloy Body

In both camera bodies, the weather and dust seals have been improved around the battery compartments and memory card doors, and increased precision in the alignment of the magnesium alloy external cover seams and in the optimal design of camera parts and structures contribute to the cameras' dust and water resistance. Internal gaskets and sealing materials are used extensively at the cameras' buttons, tripod sockets, and surrounding the LCDs. As a result, the EOS 5D Mark II now has dust and water resistance that is almost equal to that of the EOS-1N—Canon's top-of-the-line professional 35mm SLR for most of the 1990's.

Cosmetic changes on the EOS 50D include the addition of a silver coated Main Control dial with knurled wheel pattern, a classier paint finish overall and a modified rubber pad next to the grip. To increase the sensors' resistance to microscopic and larger dust particles, several improvements were made to the existing design of the Integrated Cleaning System found in the EOS 40D and in the full-frame EOS-1Ds Mark III. These improvements are found in the EOS 50D and in the newly designed, Integrated Cleaning System on the full-frame EOS 5D Mark II. The first involves the careful choice of camera components with low particle wear characteristics. Next, a fluorine coating is added to the front low-pass filter. This coating is more resistant to dust adhesion, making the use of a bulb blower (compressed air is not recommended) more effective at removing air-borne dust particles.

EOS Integrated Cleaning System

A fundamental aspect of the Integrated Cleaning System is the Self Cleaning Sensor Unit, which uses a piezoelectric element to ultrasonically shake dust off the sensor. This occurs automatically at camera startup and shutdown, and can also be activated manually via menu control. With both cameras, if sensor cleaning is manually activated, the shutter blades cycle (you'll hear a click as they do) to insure nothing on the rear of the blades could later fall onto the face of the sensor. Particles of dust that fall off during this vibration stick to absorbent materials lining the outer edges of the filter system. The third component of the Integrated Cleaning System is a software solution, allowing users to automatically "clone" any remaining dust from their RAW or JPEG images with the included Canon Digital Photo Professional (DPP) software. You can map the dust on the sensor using the Dust Delete Data function. DPP software can use that data to remove the trouble spots on all images. And unlike typical image-editing software, this automatic removal can be done to batches of images, automatically—even when the subjects in each image are completely different.

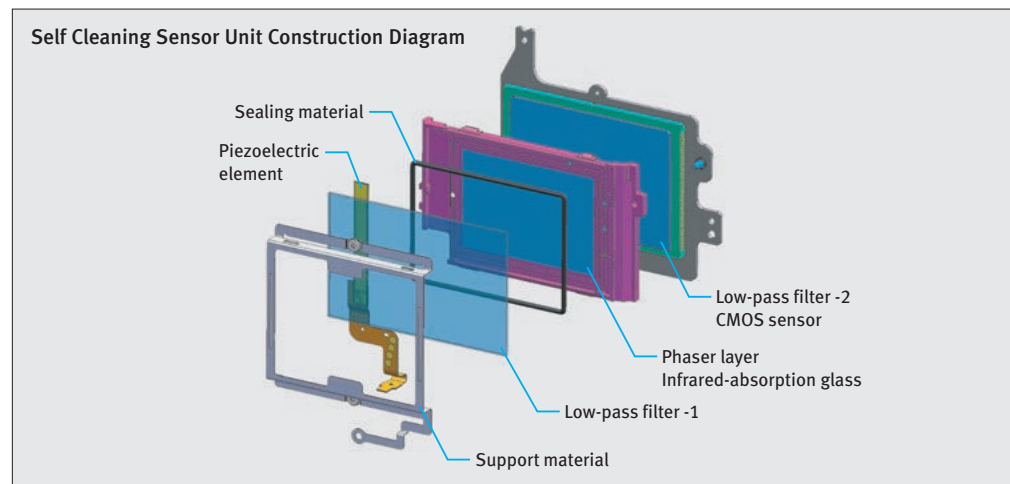
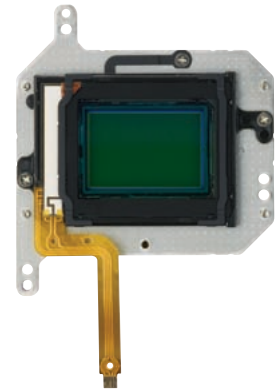

Intuitive Button and Dial Arrangement

Nearly all of the external controls and buttons on the EOS 50D are the same as those found on the EOS 40D, with two exceptions. The main control dial now includes only two camera user settings—one was deleted to make room for the Creative Auto activation setting. Also, the playback Jump button was removed below the LCD to make way for a Func. Button.

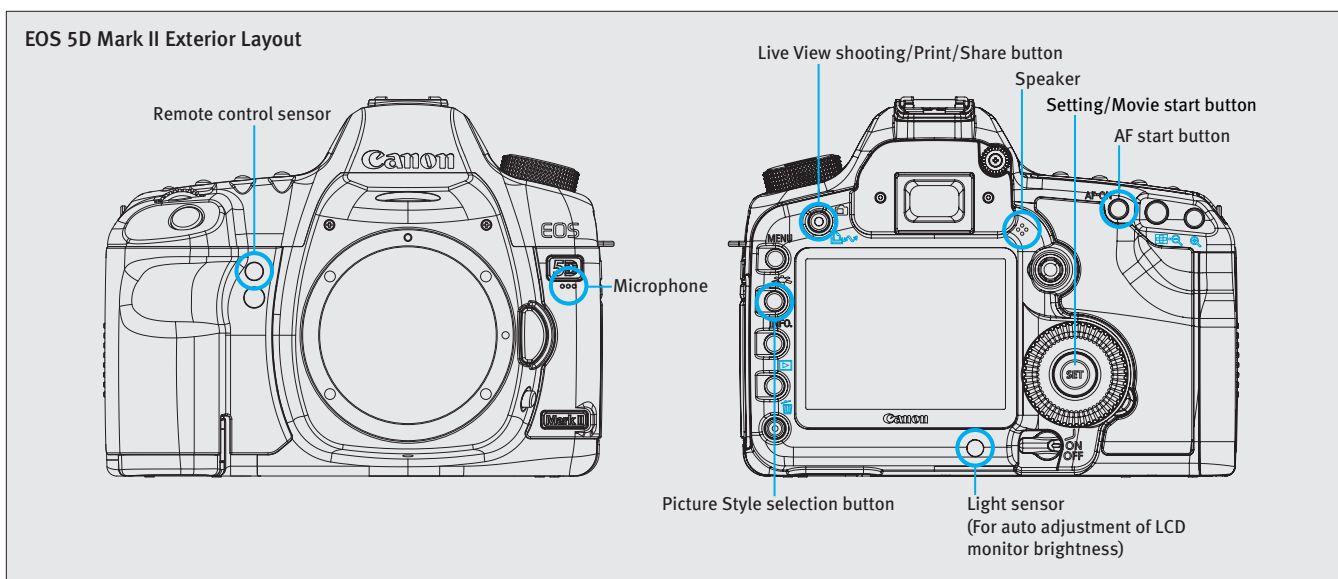

The back of the EOS 5D Mark II has undergone a fairly extensive button overhaul from the EOS 5D, and a remote control sensor and microphone were added to the camera front.

On the back of the EOS 5D Mark II, several buttons have been added or moved to facilitate Live View Function and HD video recording modes. In addition, the right thumb can easily reach the new AF-ON button, and the Live View mode activation/print button sits comfortably to the left of the viewfinder. From the top, the button arrangement is nearly identical the preceding models; with the EOS 5D Mark II, the top buttons have been re-arranged so that the most frequently-used functions are closer to the shutter button.

Increased Shutter Durability

The shutter mechanism on the EOS 50D remains unchanged from the EOS 40D, providing a rated life up to 100,000 shots and shutter speeds from 30 sec. to 1/8000 sec., with a maximum X-sync for flash at 1/250 sec. The shutter mechanism on the EOS 5D Mark II is newly designed, with an integrated shutter-cocking unit and an extended rating up to 150,000 shots. It also features shutter speeds from 30 sec. to 1/8000 sec., with a maximum X-sync for flash at 1/200 sec. Two separate motors, one dedicated to driving the mirror, and one to cocking the shutter, power the entire drive system. This two-motor system enables Live View shooting and video shooting as well. With the EOS 5D Mark II, wireless

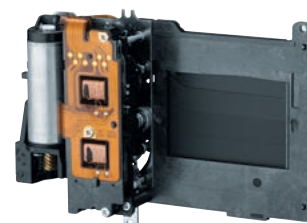

EOS 5D Mark II Shutter Unit

remote operation is now possible with Canon's small, affordable Wireless Remote Controllers RC-1 or RC-5. The optional Wireless Remote Controller RC-1 can be used to start and stop recording videos in addition to its normal still picture function. But to start and stop recording videos, it must be set to the 2-sec. timer delay mode while the camera is in Live View mode.

Action-stopping Burst Mode

Despite the increased number of megapixels on the EOS 50D compared to the 40D, the maximum burst speed remains almost the same, at 6.3 fps, with bursts up to 90 shots (JPEG, Large/Fine in high-speed continuous mode using a current UDMA CF card), up to 17 shots in RAW, and up to 10 shots in RAW+JPEG Large/Fine mode. With its outstanding frames-per-second speed and extensive burst rate, the EOS 50D is a superb, affordable choice for sports, action, event and wildlife shooters looking for a lightweight, affordable digital SLR.

Equally impressive, the 21.1-megapixel EOS 5D Mark II features an improved shooting speed of up to 3.9 fps compared to the older 12.8-megapixel EOS 5D—despite its significantly higher megapixel count. The burst depth of the EOS 5D Mark II for Large/Fine JPEG images is only limited by the capacity of the memory card when using UDMA CF cards, or up to 14 consecutive frames in RAW, or up to 13 consecutive frames in RAW+JPEG Large/Fine. This exceptional performance is made possible by improvements in the CMOS sensor with 4-channel, high-speed signal reading; DIGIC 4's excellent high-speed image processing; and the camera's DDR2 SDRAM high-speed memory buffer.

UDMA Compatibility

The duration of a continuous burst, not its maximum speed, can be affected by the speed of the memory card used. That's why Canon included support, in both cameras, for ultra-high speed Ultra Direct Memory Access (UDMA) cards up to a Mode 6 rating (max. transfer speed of up to 133MB/sec.). While Mode 6 UDMA cards aren't available yet, these two cameras will support them when they arrive. Existing UDMA cards currently run as fast as 45MB/sec. and are the fastest available. When used, UDMA cards maximize the data transfer rate in both directions between the cameras, enabling nearly twice the speed of data transfer on the EOS 50D compared to the EOS 40D.

HDMI Connectivity

More and more photographers are becoming aware of the benefits of displaying their photos on large HDTV screens or with high-resolution video projectors on bigger screens. But there's never a good laptop available when you need one, so Canon equipped both the EOS 50D and the EOS 5D Mark II with HDMI connection jacks in addition to regular A/V jacks. With the addition of an optional HDMI cable, not only can HD videos with sound be displayed on HDTV systems using a single cable connection, but also slide shows of still photos can be displayed at nearly 2.0-megapixel resolution (1920 x 1080 pixels) on HDTVs or on larger screens via HD capable video projectors. That means you can store your portfolio images on a special card (with retouching as necessary), load them back into the camera, and use it to run your large-screen presentations.

When connected, the camera communicates with the display and determines its maximum resolution (many HDTVs actually support up to 720p resolution, while others deliver up to 1080p full resolution). Once the display resolution is identified, the camera feeds it the right format signal so you get the maximum sharpness from the display.

Both the EOS 50D and EOS 5D Mark II include a standard, single-pin video-out cable for viewing images on a conventional TV. A compatible HDMI cable with “mini HDMI” connector to plug into the camera is required for hook-up to newer HDTVs; this is not included with either camera and must be purchased separately. Canon’s optional accessory mini-HDMI Cable HTC-100 or a similar third-party cable can be used.

LiveView MODE

10x Magnified View



Live View Function

Canon's spectacular Live View shooting is now available through most of the EOS Digital models. Live View Function, where the photographer can compose and shoot directly from the camera's LCD is an indispensable feature for creative photography in any number of situations. It enables the photographer to zoom in and navigate the composition 5x or 10x normal size, while enabling critical focus and allowing more attention to detail. Users can even choose a grid overlay, perfect for architectural photography. In the

studio, Live View Function can be used remotely (via a computer) through the camera's USB connection, or wirelessly if the optional Wireless File Transmitter is used.



with Grid Display

Live View Focusing

One of the elements distinguishing Canon's Live View Function from other manufacturers is the sophisticated focusing modes available, including Quick mode, Live mode, and Face Detection Live mode. In Quick mode, One-Shot AF is set automatically and the AF point is selectable even while the Live View image is displayed. In Live mode, AF can be started by pressing the AE button for either AF mode.



Face Detection Live Mode

In Face Detection Live mode, the largest face near center is detected initially, but the Multi-controller can be used to select any face detected.

Video Shooting with Live View Function

The new EOS 5D Mark II offers shooting in Full HD video—a first for EOS Digital cameras. Recordable in 640 x 480 VGA mode and in 1920 x 1080 Full HD mode, and saved as MOV files, shooting video with an EOS Digital camera increases the photographer's flexibility and allows for full-use of the camera's EF lenses including wide angle, macro, tilt-shift lenses and more (zooming is not available in shooting video). Shooting is at a frame rate of 30 fps. Sound is recorded either through the camera's built-in microphone or through an external microphone connected to the camera's microphone input terminal. Playback modes are available in-camera, and all Live View AF features can be used in shooting video.





Camera Settings and Displays

The 35-zone metering system, exposure controls, and white balance settings on the EOS 50D and EOS 5D Mark II are similar to those found on their predecessors. Data displays and menus vary depending on the model. On the EOS 5D Mark II, menu items are now accessed via top-of-the-screen tabs instead of by scrolling down, which is a major improvement over the EOS 5D, now possible because of the sharper LCD.

Creative Auto Mode

In each of the two camera, turning the Main Mode dial to the Creative Auto (CA) position accesses a new CA mode. For the inexperienced digital SLR user, CA mode is a tool that still provides full automatic operation, similar to the traditional “green zone”. But it lets users change a variety of settings to get a desired look in their pictures—without requiring extensive photographic knowledge to do so.

There are slight variations between the two models, but in each case the CA default setting is the same as the camera’s Full Auto mode. When activated, the CA mode enables you to adjust frequently used functions using a multi-position slider on the screen. Navigation from one item to another is done with the camera’s rear 8-way multi-controller, and once you’re at a certain setting, you adjust it by turning either of the camera’s input dials. All of these can be accessed from one screen for a more direct, intuitive approach designed to appeal to novice users or to advanced photographers in a hurry.

CA settings on the EOS 5D Mark II include Background (from blurred to sharp), Exposure (from Darker to Brighter), Picture Style (Standard, Portrait, Landscape, and Monochrome), Recording Quality (pressing the SET button also brings up this screen), and Drive Mode (Single, Continuous, and 10-sec timer).

The CA mode settings on the EOS 50D include the Flash Mode (auto, on and off), Background (from blurred to sharp), Exposure compensation (Darker to Brighter), Picture Style settings (Standard, Smooth Skin Tones, Vivid blues and greens and Monochrome), Image-recording quality (all RAW, JPEG, and RAW+JPEG settings) and Drive mode (Single, Low-speed continuous, and self timer).

Creative Auto Settings





Creative Auto setting method: Turn the Mode Dial to [CA] (Creative Auto). The setting screen will then appear on the LCD monitor. Press the Multi-controller, then use it to select the function. Turn the Main Dial or Quick Control Dial to select the desired setting.

Setting screen Shooting screen

Exposure compensation and Auto Exposure Bracketting can now be set using the same screen, enabling you to quickly check the overall exposure amount when combining both. The screen now shows a “Darker” and “Brighter” indication above the exposure scale, easier to read than the plus and minus signs when holding the camera at arms length in Live View mode. To set exposure compensation only, it’s possible to bypass this combined control by using the Quick Control Dial, just as on previous models.

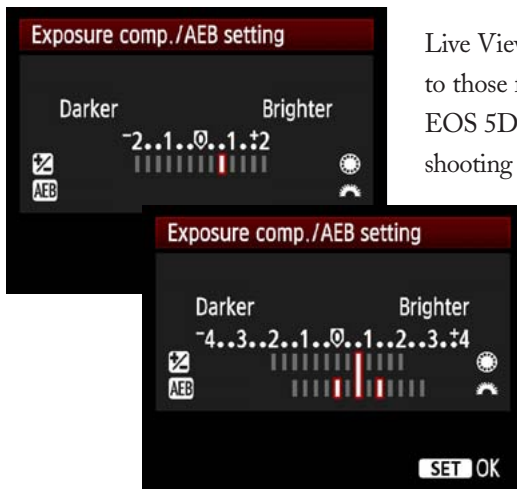

Setting Exposure Compensation and AEB

Live View shooting control screens have also been combined and optimized (compared to those found on the EOS 40D) in order to speed access to a variety of settings. On the EOS 5D Mark II, the Live View Function screen also includes a choice for disabling still shooting during video recording or disabling video recording altogether. Another screen gives you access to Exposure Simulation and screen brightness settings, while a third lets you change the AF mode to Quick, Live, or Face Detection Live mode. Evaluative metering is automatically set for Live View mode, but while Live View mode is activated you can still toggle back and forth to the main menu screen by pressing the menu button in order to change drive modes, ISO speed, Picture Style settings, and other settings. (Previous EOS models, such as the EOS 40D, required lowering the mirror and shutting down Live View Function to access the camera’s menu.)

Two different grid displays are now available to aid composition in Live View mode, the newest offering a tighter grid pattern. You can also select two Silent Shooting modes: The first activates the 1st curtain electronic shutter while the mechanical shutter is open (a quiet step), followed by a reduced-noise shutter cocking. In Mode 2, the shutter cocking does not occur at all until you lift your finger from the shutter button, allowing you to decide when camera sound of any kind would be appropriate.

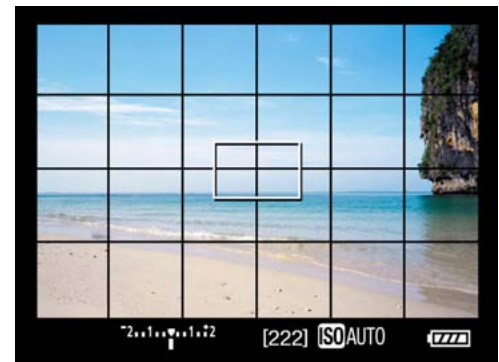

Grid Display

On the EOS 5D Mark II, the top-mounted LCD panel is slightly larger, and settings are easier to read than on the EOS 5D. Also, ISO speed, D+ (Highlight Tone Priority) and remote control indicators have been added. The functions and positions on the three buttons in front of the top LCD panel have been changed so that the most frequently used buttons are near the Main Dial.

On the back of the EOS 5D Mark II, the new AF-ON button has been added to the left of the AE lock button. The former Jump button has been changed to the Picture Style selection

button, and the Direct print button changed to the Live View shooting/Print/Share button. In addition, during video recording you can use the SET button to start or pause videos. Finally, activating the Live View Function is now done using the Print/Share button located next to the viewfinder instead of the SET button. This change allows the SET button to be used as normal to select menu items when the Live View mode is activated, or to start and stop video recording.

Image Quality Controls

The increased resolution and anti-reflective coatings on the 3.0-inch, 920,000-dot Clear View LCD make it much easier to read the numerous image quality control screens, while the speed of the DIGIC 4 Image Processor provides much faster access to the individual screens. Added screen colors also give the menus, animations and settings a more refined look and feel, with easier to read fonts. While the image quality screens contain similar choices to those found in previous models (including the same white balance, color space, Picture Style, and WB SHIFT/BKT controls), 25 languages are now supported, and the date and time can now be set to the exact second.

Playback Controls and Displays

Both cameras have dramatically improved playback image quality as a result of the new LCD. In addition to higher resolution, improved viewing angle, and anti-reflective coatings, the color saturation and reproduction accuracy are superior to previous LCDs, and approach the full sRGB color space. The sharpness improves the 9-image thumbnail display, and details really pop in the new 4-image thumbnail screen.

As for playback controls, the EOS 5D Mark II gets the majority of improvements and changes to its playback controls and display screens, thanks in part to its HD video recording function and the older LCD features on the EOS 5D. In addition to the Single-image display screen, there is now a Single image+ Image-recording quality screen, and a separate shooting information display. A new histogram with brightness and RGB graphs is also provided. With the Jump function now moved to the main dial, it's easier to move from image to image or through videos. You can set the jump function to 1, 10, or 100 images or, more specifically, to Screen, Date, Folder, Movies, or Stills options via a setting in the Playback menu. Checkmarked images or all images in a specific folder can be deleted, while another choice lets you delete all images on a card without reformatting it.

Creative controls in the Slideshow mode (formerly the Auto Play mode) on both cameras have been expanded to take advantage of the high resolution HDMI out connection (and optional HTC-100 cable). Once photographers realize its multimedia power and capability, fewer will be trucking their laptops to presentations and instead will be loading their images and edited videos (with the EOS 5D Mark II) onto memory cards. You can now set the playback time for displaying images to between 1–5 secs., and additional playback filters include displaying all images, by folder and by date. On the EOS 5D Mark II, video or still options are added.

My Menu and User Settings

Up to six frequently used menu items and Custom Functions can be registered in the My Menu custom control. It provides nearly immediate access to settings a photographer finds he or she frequently needs to access and change on-the-fly, and eliminates the need to move from one menu screen to another when changing multiple settings. When the custom function “Display from My Menu” is enabled, pressing the menu button will display the My Menu screen first, regardless of which menu items were most recently viewed. Modifying or registering items in the My Menu control can be done manually, or by using the supplied Canon EOS Utility software, allowing you to save multiple “My Menu” registrations for a variety of users or shooting situations.

Another short-cut for photographers are the two available Camera User settings, which are the C1 and C2 positions on the Main Dial (the EOS 5D Mark II adds a third C3 setting). With these settings, a photographer can set his or her camera up for almost any situation they may frequently encounter, register (memorize) the active settings, and then through the “Camera User Setting” menu option, apply them to one of the available settings on the Mode Dial. A wedding photographer who frequently shoots flash-on-camera images, for example, could register settings like Manual exposure mode at 1/250th and f/8, ISO 400, +1/3-stop flash exposure compensation, Neutral Picture Style, Large/Normal JPEG image quality, and any combination of Custom Functions they like to use for this shooting. Now, whenever that photographer goes indoors and needs to take flash pictures, all that’s needed to get back to those settings is to turn the Mode Dial to the appropriate “C” setting.

Custom Function and Controls

Almost all functions, including image quality, Live View Function, video recording (on the EOS 5D Mark II) and Custom Function settings can be registered into the User Settings. And any of these pre-registered settings can be changed as needed during shooting, when taking pictures in the C1, C2 or C3 Camera User modes. Custom Functions: A longer list of new features on the EOS 5D Mark II have led to the several new Custom Function controls. High ISO speed noise reduction settings include Standard, Low, and Strong, and there are now Custom Functions for Highlight Tone Priority, Auto Lighting Optimizer and the AF Microadjustment settings. In all, there are 25 custom functions on the EOS 5D Mark II with a total of 71 settings.

The EOS 50D likewise has an expanded range of available Custom Functions for the creative photographer. For example, flash sync speed in Av mode can now be set to work similarly to some competitive digital SLRs, automatically choosing a flash sync speed between 1/60 sec. and the maximum of 1/250 sec. based on the lens focal length and ambient lighting conditions. (Previous options for flash in Av mode, such as locking flash sync at the camera’s fastest sync speed or the default slow-sync in low light, remain available as well.)

The Auto Lighting Optimizer Custom Functions are the same on the EOS 50D as on the EOS 5D Mark II. However, a new FUNC. button has been added to the EOS 50D,

positioned next to the left of the power switch on the camera back. Via the Custom Function menu, you can assign a variety of controls to that button (as you could on the EOS 40D's Jump button) including LCD Brightness, Image Quality, Exposure Compensation/AEB, Image Jump and Live View Function settings.

Previously, some Live View settings were made in the Set-up Menu, and some in the camera's Custom Function menu. For easier operation, both the EOS 50D and EOS 5D Mark II now have all relevant Live View settings in one place in the Set-up Menu—there's no need to access Custom Functions.

AF Microadjustment

Both models now feature an improved version of the AF Microadjustment custom function (C.Fn III-8 on the EOS 5D Mark II and C.Fn III-7 on EOS 50D) previously found in the flagship EOS-1Ds Mark III and the EOS-1D Mark III cameras. This powerful tool allows you to fine-tune the focus precision when individual lenses are used, or apply an overall correction that's used with all lenses. In the past, this required sending a specific lens and camera to a Canon Service Center. Now, with this tool, you can make fine adjustments to your camera's AF system for slight focus variations that may occur as lens mechanisms wear, or to compensate for variations in tolerances. Correction data for up to 20 lenses, including the kit lens, can be stored in the camera. To make room for other lenses, these can be deleted individually as necessary.

Using AF Microadjustment requires taking a series of test shots with the camera focused on a precise subject, with foreground and background clearly visible. Shooting test images with different Microadjustment values, it's possible to select which setting gives the best results after viewing the images at 100% in your computer. You then set that value up to +/- 20, using the AF Microadjustment Custom Function screen.

In the Microadjustment custom function window, you can choose to correct focus for all lenses or individual lenses. For either, pressing the INFO button brings you to a second screen with a +/- 20 analog scale. Here's where the focus locking position of the lens can be adjusted forward or backward in up to 20 fine increments in either direction.

The amount of adjustment for one step varies based on the maximum aperture of the lens. When saved, the camera's autofocus system will continue to operate in normal fashion, but the precise plane of sharpest focus will be moved forward or backward based on the AF Microadjustment settings. The adjustment information for a lens (or camera) can be disabled or easily readjusted, and does not apply to other cameras using the same lens.

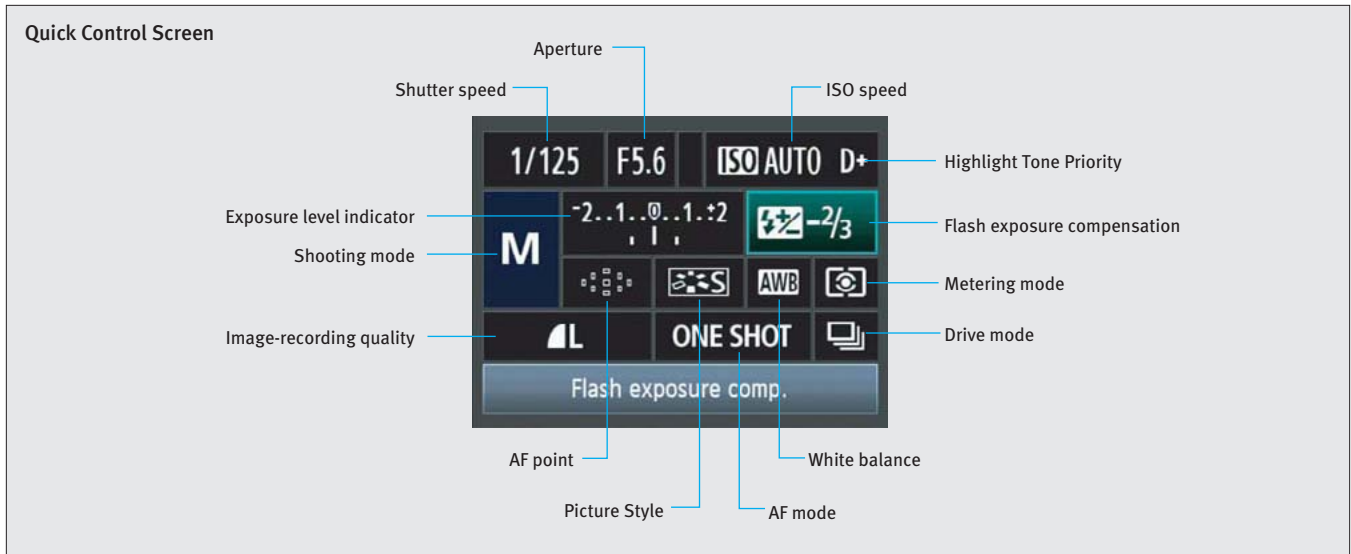

Quick Control Screen

Faster access to a wide variety of controls is now possible using the Quick Control Screen on both cameras, activated by pressing the Multi-controller. Once it's visible, moving the 8-way multi-controller up, down, left, right or diagonally lets you jump from one function area to another. When you reach the right function area, turning either the Main Dial or the Quick Control Dial changes the settings, while pressing the SET button brings up the full control screen for that function. Another related feature: The LCD can be set to display a group of Camera Settings or Shooting Functions by pressing the INFO button. With shooting functions displayed, the settings on the top LCD panel are now duplicated on the large 3.0-inch LCD. If you press the ISO speed button or any other button while the shooting functions are displayed, the respective full screen will appear.

Printing and Camera Direct Controls

Minor additions to the Direct Printing (PictBridge) and Print Ordering (DPOF) controls are included on both cameras. The latest PictBridge features such as reflecting printing effects in the thumbnails, and image tilt correction have been included. Also, RAW images can now be printed, but videos or individual video frames on the EOS 5D Mark II cannot be printed.

Since folders can now be added to the memory card, DPOF controls include the ability to specify images in their respective folders. This ability has also been added to the Direct Image Transfer function, which can now be used to transfer videos and still photos from the EOS 5D Mark II.



New Features in EOS Utility and DPP

Unlike many competitive DSLR models that come with only basic download and view software applications, both the EOS 5D Mark II and EOS 50D comes bundled with Canon's Digital Photo Professional (DPP) version 3.5, a powerful—and free—RAW conversion and optimization utility. DPP features an intuitive user interface and an integrated browser that speeds the selection, cropping, and export of both RAW and JPEG images, either as single images or as multiple images in batch processing mode. Among its powerful RAW conversion utilities, DPP contains sophisticated exposure and white balance controls, adjustable Picture Style settings, noise reduction controls and lens aberration correction with more power than the camera's built-in Peripheral Illumination Correction (PIC) function. There's also Chromatic Aberration correction for RAW images which can be applied before they're processed.

RAW images from the EOS 50D and EOS 5D Mark II require DPP version 3.5 or higher. But DPP v.3.5 is also compatible with RAW files from previous EOS Digital SLRs, going back as far as the 3.0-megapixel EOS D30. Version 3.5 can also process RAW images from the compact PowerShot G10 camera (however, it cannot process RAW files from earlier PowerShot models).

In addition to DPP, both cameras will include the following programs on the EOS Digital Solution Disk Ver.19.1:

- EOS Utility 2.5.1 (Win/Mac)
- Picture Style Editor 1.4.1 (Win/Mac)
- ZoomBrowser EX 6.2.1 (Win)
- ImageBrowser 6.2.1 (Mac)
- PhotoStitch 3.1/3.2 (Win/Mac)
- Memory Card Utility 1.2 (Win/Mac)
- WFT Utility 3.2 (Win/Mac)
- Original Data Security Tools 1.5 (Win)
- Win 2000 driver (Vista and XP has a built-in driver)

Zoombrowser EX 6.2.1 and ImageBrowser 6.2.1 will also include updated controls that enable basic clip editing of movies shot with the EOS 5D Mark II.



Battery Grip EOS 50D: Battery grip BG-E2N with Battery Magazine BGM-E2

This optional grip is the same as the EOS 40D's, and was designed to extend shooting capacity and enable vertical shooting. Constructed out of magnesium alloy with weather and dust resistant seals around the battery compartment, the grip includes a vertical shutter button, auxiliary main input dial, AF point selector button and DC coupler cord mount. With batteries loaded, the grip adds heft and overall balance that is closer to that of the EOS-1Ds Mark III body. There are two power choices: it can be loaded with either one or two BP-511A lithium-ion Battery Packs or with six AA-size batteries (using the included battery magazine). When loaded with two BP-511A Battery Packs, normal shooting capacity doubles to approximately 1,200 shots (at 50% with built-in flash, at 73 degrees F operating temperature) or up to 340 shots in Live View shooting mode.

**EOS 5D Mark II: Battery Grip BG-E6 with battery magazine BGM-E6**

Exclusively for the EOS 5D Mark II, the new BG-E6 features a magnesium alloy body and sealed battery compartment that complements the ruggedness of the EOS 5D Mark II, as well as extending the camera's versatility and shooting capacity. It provides a comfortable grip and array of controls for shooting in vertical orientation, as well as two power options: either one or two LP-E6 lithium-ion Battery Packs, or six AA-size alkaline batteries. When loaded with dual LP-E6 lithium-ion Battery Packs, detailed battery information and recharge performance is communicated to the camera, and shooting capacity is doubled, to roughly 1,700 shots (at 73 degrees F), or approximately 400 shots when using Live View shooting mode.



Wireless File Transmitters**EOS 50D: Wireless File Transmitter WFT-E3A* (firmware version 2.0.0 or later required)**

This Wireless File Transmitter is the same model designed for the EOS 40D, and elegantly mounts to the base of either camera. It has full vertical shooting controls, enhancing its usefulness for photographers working on location or in the studio. This device allows seamless connection to a wireless access point or computer (located up to 492 feet from the camera), and enables wireless control of the camera (with preview in Live View mode) using included EOS Utility software. Three different wireless operation modes are possible: FTP, PTP, and HTTP. Furthermore, a USB 2.0 Hi-Speed connection allows plugging-in an external storage device such as a portable hard drive or USB GPS unit. Finally, in areas where there's interference or lots of wireless transmission, an Ethernet port for attaching the camera to a wired network or personal computer at distances up to 1,000 feet.

**EOS 5D Mark II: WFT-E4A***

The new WFT-E4A is dedicated strictly to the new EOS 5D Mark II and features high speed image transfer (802.11b/g Wi-Fi connectivity via FTP, PTP or HTTP). Wireless transfer of images is possible to a wireless access point or computer up to 492 feet from the camera. This unit enables wireless control of the camera from a computer (with preview in Live View mode, as well as focus control) running the included EOS Utility Software. A USB 2.0 Hi-Speed connection can be used for attaching external storage media (including USB thumb drives) or a compatible USB GPS unit, allowing position information to be included with recorded images. Another option is wired Ethernet, using conventional Ethernet cables up to 1,000 feet from the host computer. The WFT-E4A also acts as a fully functional vertical grip with shutter, exposure and AF point selection controls.



* WFT-E3A and WFT-E4A are sold in the USA and other countries where laws require wireless devices with 11 channels of operation. WFT-E3 and WFT-E4 are sold in countries where laws permit 13 wireless channel devices.

Canon EF 24mm f/1.4L II USM lens

This new wide-angle lens offers far more than a cosmetic makeover to the highly acclaimed EF 24mm f/1.4L USM lens it replaces, and it retains the distinction of being the brightest wide-angle L-series lens in its class. Added professional characteristics include dustproof and weatherproof construction, with dramatic improvements to image quality provided by a total optical re-design and the application of Canon's exclusive Subwavelength Structure Coating (SWC) to the inside surface of the large front lens element. This special coating is designed to minimize ghosting and flare, especially from extreme off-angle light rays. It combines with traditional Super Spectra multi-coating, to give the lens unprecedented resistance to internal reflections and flare.

Ultra-low Dispersion (UD) glass lens elements were also added in order to reduce chromatic aberrations, and a high speed CPU and improved algorithms make possible a faster and quieter autofocus system. Combined with two aspherical lens elements, the lens offers significant improvements in image quality and contrast, especially at the outer edges of the image when used on full-frame digital SLRs. A circular aperture means beautiful out-of-focus highlights in backgrounds. This new lens targets the critical professional photographer, and should be especially prized by users of high-resolution full-frame digital cameras like the new EOS 5D Mark II.

External View, Cross Section and Optical System of of EF 24mm f/1.4L II USM

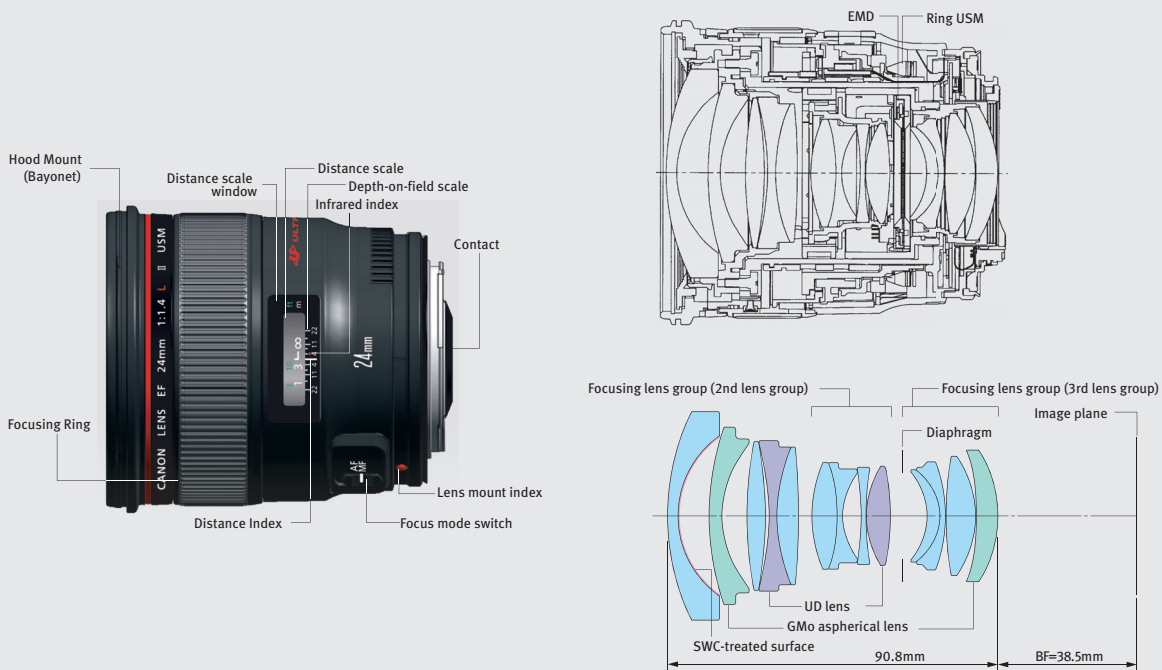

**Canon EF-S 18-200mm
f/3.5-5.6 IS lens**

This new high magnification, wide-to-telephoto EF-S zoom lens is the ideal kit lens for the EOS 50D, offering a 35mm equivalent focal length of 29mm to 320mm (11x), and featuring Canon’s advanced Optical Image Stabilizer technology. It is also available separately and is compatible with all Canon DSLRs using APS-C sized sensors, including the EOS 40D, 30D, 20D, and all versions of the EOS Digital Rebel and Rebel series cameras.

The compact size and weight on this lens, plus its professional lens design and construction, improved AF speed and advanced IS system make it an extraordinary value for the price. The optical arrangement includes two UD glass elements and two high-precision GMo (Glass Molded) aspherical lenses among the total of 16 lead-free glass elements in 12 groups. These UD and aspherical lens elements help reduce distortion and chromatic aberrations. Close-focus performance is excellent: the lens focuses down to about 1.5 feet (0.45m), where it can fill the frame with a subject about the size of a book of matches. In addition, Super Spectra Coatings on all elements help to minimize lens flare and ghosting.

Canon’s advanced Optical Image Stabilizer technology increases the lens stability by up to 4 shutter speeds, essentially extending the performance of the lens in low-light situations to that of more expensive f/2–f/2.8 non-stabilized lenses. For example, at 200mm focal length, the recommended lowest shutter speed for sharp photos is 1/200 sec. But with the IS turned on, most photographers will be able to take sharp photos at speeds as slow as 1/30th sec. or even 1/15th sec., allowing creative control of the aperture to increase depth of field, balance the ambient lighting to reduce underexposed backgrounds, or increase motion blur as desired.



The advanced Image Stabilization system also senses camera motion and automatically optimizes the Image Stabilization for either normal shooting or panning (where vertical stabilization is applied, but horizontal isn't to allow for side-to-side panning). The Image Stabilization system also has a function that detects the use of a tripod and responds accordingly. Other features that add to image quality are the 6-blade, circular aperture for exquisite soft-toned images, and the high speed, optimized AF system. As a finishing touch for convenience and safety, the lens includes a built-in zoom locking mechanism that holds the lens to its shortest, un-extended length.

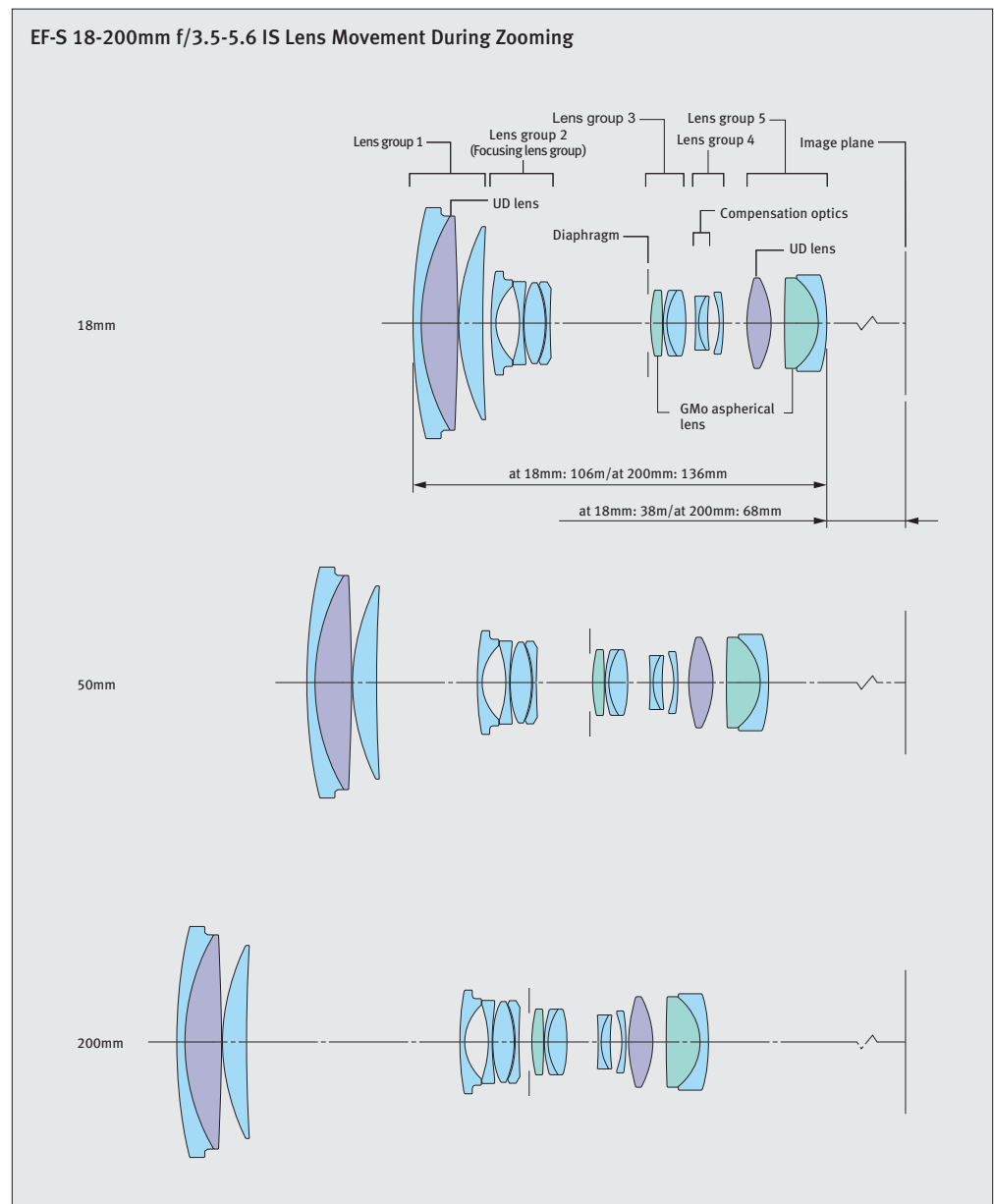



EOS 50D

Imaging Sensor

Resolution:	Approx. 15.1 million effective pixels (4768 x 3174 pixels)
Sensor Size:	22.3 x 14.9 mm
Sensor Type:	Canon CMOS Sensor
Pixel Size:	4.7 microns square
Lens focal length factor:	1.6x
Sensor Dust Removal:	EOS Integrated Cleaning System <ul style="list-style-type: none"> • Active removal of dust by vibrating front low-pass filter • Front low-pass filter has new fluorine coating to further resist adhesion of dust • Automatic removal of dust spots using Canon Digital Photo professional software

Performance

Maximum frames-per-second:	6.3 fps
Maximum Number of Frames / Burst:	<ul style="list-style-type: none"> • JPEG: 60 (90 w/ UDMA cards) • RAW: 17 • RAW + JPEG: 11
Shutter Speeds:	30 seconds ~ 1/8000, plus Bulb
Flash Sync Speed:	Up to 1/250, with Canon EX-series Speedlites
Anticipated Shutter Durability:	Approx. 100,000 frames
Computer Interface:	USB 2.0 (Hi-speed)

Image Recording

Storage Media:	<ul style="list-style-type: none"> • CF Type I and II memory cards • Recording to external media enabled with WFT-E3/E3A (with firmware update to WFT unit)
Card Compatibility:	<ul style="list-style-type: none"> • OK for cards over 2GB • High-speed writing with UDMA CF cards
Image Format and Resolution Options:	<ul style="list-style-type: none"> • JPEG ▪ Large – 4752 x 3168 (approx. 15.1 million pixels) ▪ Medium – 3456 x 2304 (approx. 8.0 million pixels) ▪ Small – 2352 x 1568 (approx. 3.7 million pixels) • RAW – Canon .CR2 file format • sRAW1 – 3267 x 2178 (approx. 7.1 million pixels) • sRAW2 – 2376 x 1584 (approx. 3.8 million pixels) • RAW + JPEG – JPEG files written as separate file on card • sRAW1 + JPEG • sRAW2 + JPEG
Analog to Digital Conversion:	14 bits per channel

Image Processor:	Canon DIGIC 4
File Numbering:	DCIM standard <ul style="list-style-type: none"> • sRGB color space: IMG_0001.jpg, or IMG_0001.cr2 • Adobe 1998 color space: first character is an underscore (_)
Folders:	<ul style="list-style-type: none"> • Automatically created for image storage • New folders can be user-created • Folders can be freely selected on the memory card by the photographer
Data Verification:	<p>“Original Image Data” can be appended to each image via Custom Function</p> <ul style="list-style-type: none"> • Requires optional Canon Original data Security Kit OSK-E3 to check authenticity

Live View Function

Viewing options:	<p>Camera’s LCD monitor</p> <p>Computer monitor, tethered via USB</p> <p>Computer monitor, wirelessly via WFT-E3/E3A</p>
Manual Focus:	Viewed on LCD monitor, with option to magnify 5x or 10x
Auto Focus:	<p>Possible</p> <ul style="list-style-type: none"> • “Quick Mode” 9 point phase-difference AF (mirror drops momentarily, AF via AF sensor) • “Live Mode” (uninterrupted Live View; Single point, contrast-based off of imaging sensor) • “Face Detection Live Mode” (Face detection, contrast-based)
Shutter Response in Live View:	59 ms.
Silent Mode Live View Shooting:	Yes (Mode 1, and Mode 2)

LCD Monitor

LCD Monitor:	<p>New clear view LCD monitor</p> <ul style="list-style-type: none"> • 3.0 inch (diagonal) TFT color; approx. 100% coverage • Approx. 920,000-dot resolution • Approx. 160° viewing angle
LCD Monitor Brightness Levels:	<ul style="list-style-type: none"> • Adjustable in 7 levels

Autofocus System

Number of AF Points:	<ul style="list-style-type: none"> • 9 – cross-type usable with all lenses <i>f</i>/5.6 and brighter • 1 – Diagonal “High-precision” cross-type sensor at center, lenses <i>f</i>/2.8 and brighter • Manual point selection
AF Point Selection:	<ul style="list-style-type: none"> ▪ C.Fn III-3-1/2 allows with the Multi-controller, or Quick Control Dial to be used directly to control the AF point • Automatic Selection
AF Activation:	Pressing the shutter release halfway (SW-1), or pressing the “AF-ON” button

- AF Modes:
- One Shot AF
 - AI Servo AF
 - AI Focus AF
 - Camera automatically switches between One Shot AF and AI Servo AF
- AF Sensitivity Range: EV -0.5 ~ 18 (measured at 73°F and ISO 100)
- AF Microadjustment: C.Fn III-7
- Adjust all by same amount, or Adjust by Lens

Exposure Control

- Shutter Speeds: 30 seconds ~ 1/8000, plus Bulb; x-sync at 1/250 sec.
- ISO Range: ISO 100 ~ 3200
- H1: 6400, H2: 12,800
- Auto ISO: ISO 100 ~ 1600 in Basic Zone Modes
- Exposure Modes: Manual, Aperture Priority (Av), Shutter Priority (Tv), Program AE, and camera user (C1, C2 settings)
- Full Auto Modes: Green Zone, Portrait, Landscape, Close-up, Action, Night Portrait, Flash Off, Creative Auto
35-zone metering sensor
- Metering:
- Evaluative Metering (linked to active AF points)
 - Center-weighted Metering
 - Partial Metering (Center, approx. 9% of viewfinder)
 - Spot Metering (Center, approx. 3.8% of viewfinder area)
- EV 0 ~ 20 (all patterns at normal temperatures)
- Metering Range: Possible in P, Tv, Av, and A-DEP Exposure Modes
- Exposure Compensation: ± up to 2 stops, in 1/2 or 1/3-stop increments
- Possible in P, Tv, Av, and A-DEP Exposure Modes
- Auto Exposure Bracketing: ± up to 2 stops, in 1/2 or 1/3-stop increments
- Automatic Image Correction Tools:
- Auto correction of Lens Periphery Illumination
 - Correction for specific lenses can be registered in camera using Canon EOS Utility software
 - Auto Light Optimizer
 - Highlight Tone Priority Mode

Flash

- Compatible Flashes: All Canon EX-series Speedlites
- Camera Menu Sets flash: Yes (580EX II, and 430EX II only)
- E-TTL II Flash Metering: Flash metering NOT linked to active AF point
Distance from compatible EF lenses now used
- Wireless: E-TTL Fully compatible
- Flash Exposure Compensation: Up to ±2 stops in 1/3 or 1/2 stop increments

- Built-in Flash:** Guide number at ISO 100 = 43 feet
- Sync Contacts:**
- Accessory shoe: X-sync contact (syncs at 1/250 sec. or slower)
 - PC terminal
 - X-sync at 1/125 sec.
 - No polarity
- Both the accessory shoe and PC terminal can be used simultaneously

Viewfinder

- Viewfinder:** Fixed pentaprism
- Coverage: approx. 95%
 - Magnification: approx. 0.95x
 - Eye point: 22 mm (from eyepiece lens center)
- Viewfinder:** Ef-A provided as standard
- Available options:
 - Ef-D: Precision Matte w/Grid Lines
 - Ef-S: Super Precision Matte
- Dioptric Adjustment:** Adjustable from: -3.0 ~ +1.0

Image Control

- Color Space:** sRGB, and Adobe RGB 1998
- White Balance:** 2500°K ~ 10,000°K
- White Balance Correction:** ±9 levels Blue/Amber shift
±9 levels Magenta/Green shift
- White Balance Bracketing:** Yes
- Picture Style:** 6 – Standard, Portrait, Landscape, Neutral, Faithful, Monochrome
3 – User sets available

Interface

- Computer Connection:** High-speed USB, mini-B port
- Wireless Transmitter:** WFT-E3/E3A (requires firmware update for compatibility)
- Serial USB
 - 802.11b/g wireless networks
 - Ethernet
- Remote Control:** Canon N3-type terminal
- Video-out:** NTSC or PAL Video formats (selectable on menu)
- HDMI
 - Single-pin mini-jack to Standard RCA video-out port

Direct Printing

Compatibility:	PictBridge <ul style="list-style-type: none"> ▪ BubbleJet Direct, and CP Direct not supported
Compatible Images:	RAW, sRAW, and JPEG images
Preview Controls on Camera's LCD:	Paper size, Paper types, Printing effects, Layout, Trimming, Tilt-correction ($\pm 10^\circ$ in 0.5° increments), Date and Time imprinting
Connection to Printer:	USB
DPOF Image Marking:	Complies with DPOF version 1.1 specifications

Power Supply

Battery:	1 – Canon BP-511A
Charger Unit:	Included: CG-580 Optional: CB-5L, or CA-PS400
AC Adapter:	Optional: AC Adapter Kit ACK-E2
Battery Grip:	Optional: BG-E2N, or BG-E2 <ul style="list-style-type: none"> • 2 – Canon BP-511A Battery Packs can be used, or • 6 – AA size batteries with supplied insert
Date/Time Back-up Battery:	Lithium-ion CR2016 button battery (approx. life: 5 years)

Body

Exterior Material:	Magnesium alloy
Chassis Material:	Stainless steel, and Polycarbonate with glass fiber
Lens Mount:	Canon EF Lens mount; Metal
Lens Compatibility:	All Canon EF and EF-S lenses
Operating Temperature Range:	$0^\circ \sim 40^\circ \text{ C}$ $32^\circ \sim 104^\circ \text{ F}$
Operating Humidity:	85% or less
Dimensions (W x H x D):	145.5 x 107.8 x 73.5 mm 5.7 x 4.2 x 2.9 inches
Weight (without battery or memory card):	730 g. 25.7 oz.

EOS 5D Mark II

Imaging Sensor

Resolution:	Approx. 21.1 million effective pixels (5616 x 3744 pixels)
Sensor Size:	24 x 36 mm
Sensor Type:	Canon CMOS Sensor
Pixel Size:	6.4 microns square
Lens focal length factor:	1.0x – Full Frame 24 x 36 mm – no lens conversion factor
Sensor Dust Removal:	<ul style="list-style-type: none"> • EOS Integrated Cleaning System <ul style="list-style-type: none"> ▪ Active removal of dust by vibrating front low-pass filter ▪ Front low-pass filter has new fluorine coating to further resist adhesion of dust ▪ Newly-designed Self Cleaning Sensor Unit optimized for the EOS 5D Mark II's full-frame CMOS sensor • Dust Delete Data Function <ul style="list-style-type: none"> ▪ Automatic removal of dust spots using Canon Digital Photo professional software <ul style="list-style-type: none"> • The XY-coordinates of dust adhering to the low-pass filter is detected by shooting a test shot. Information is appended to subsequent images. • Dust Delete Data information is then used by Canon DPP software (included) to automatically remove dust spots • Manual Cleaning

Performance

Maximum frames-per-second:	3.9 fps (at 1/500 sec. or faster, at all image-quality settings)
Maximum Number of Frames / Burst:	<ul style="list-style-type: none"> • JPEG: Unlimited (with UDMA CF Card); 78 (with non-UDMA CF card) • RAW: 14 (with UDMA CF card); 13 (non-UDMA CF card)
Shutter speeds:	30 seconds ~ 1/8000, plus Bulb
Flash Sync Speed:	Up to 1/200, with Canon EX-series Speedlites
Anticipated Shutter Durability:	Approx. 150,000 frames
Computer Interface:	USB 2.0 (Hi-speed) <ul style="list-style-type: none"> • Improved, faster transmission speed from the EOS 5D model
Start-up Time:	0.1 sec.

Image Recording

Storage Media:	<ul style="list-style-type: none"> • CF Type I and II memory cards • Recording to external media enabled with WFT-E4/E4A
Card Compatibility:	<ul style="list-style-type: none"> • OK for cards over 2GB • High-speed writing with UDMA CF cards

Image Format and Resolution Options:	<ul style="list-style-type: none"> • JPEG <ul style="list-style-type: none"> ▪ Large – 5616 x 3744 (approx. 21.0 million pixels) ▪ Medium – 4080 x 2720 (approx. 11.1 million pixels) ▪ Small – 2784 x 1856 (approx. 5.2 million pixels) • RAW – Canon .CR2 file format <ul style="list-style-type: none"> ▪ RAW – 5616 x 3744 (approx. 21.0 million pixels) ▪ sRAW1 – 3861 x 2574 (approx. 10.0 million pixels) ▪ sRAW2 – 2784 x 1586 (approx. 5.2 million pixels) ▪ RAW + JPEG – JPEG files written as separate file on card ▪ sRAW1 + JPEG ▪ sRAW2 + JPEG • MOV <ul style="list-style-type: none"> ▪ Full HD – 1920 x 1080 (16:9 format) ▪ SD/VGA – 640 x 480 (4:3 format)
Analog to Digital Conversion:	14 bits per channel
Image Processor:	Canon DIGIC 4
File Numbering:	DCIM standard <ul style="list-style-type: none"> • sRGB color space: IMG_0001.jpg, or IMG_0001.cr2 • Adobe 1998 color space: first character is an underscore (_)
Folders:	<ul style="list-style-type: none"> • Automatically created for image storage • New folders can be user-created • Folders can be freely selected on the memory card by the photographer
Data Verification:	<p>“Original Image Data” can be appended to each image via Custom Function</p> <ul style="list-style-type: none"> • Requires optional Canon Original data Security Kit OSK-E3 to check authenticity

Movie Shooting and Playback

Recording Format:	MOV (Video: H.264, Sound: Linear PCM)
Movie Recording Size:	<ul style="list-style-type: none"> • Full HD – 1920 x 1080 (16:9 format) • SD/VGA – 640 x 480 (4:3 format)
Frame Rate:	30 fps
Still Capture during Movie Shooting:	<p>Still photos can be captured at any time by pressing the shutter release. The still will be captured at the image quality settings currently set.</p> <p>Note: When a still image is captured, the movie will be interrupted momentarily. Live View returns, and the movie recording resumes automatically after the still is captured</p>
Movie Retouching and Effects:	Based on set Picture Style

- Sound Recording:
 - Monaural recording using the built-in microphone
 - Stereo recording via optional external microphone using input port
 - Sound recording ON/Off selectable in menu
 - Sound volume adjusted automatically
 - Compatible with both condenser-type or dynamic external microphones
- Continuous Movie Recording Time:
 - Full-HD video – approx. 12 minutes
 - SD-video – approx 24 minutes
- Focusing:
 - Autofocus
 - Quick Mode
 - Live Mode
 - Live View Face Detection Mode
 - Manual
 - Magnified MF on LCD not possible
- Exposure:
 - Program AE for shooting movies
 - Live View Movie – Center-weighted metering
 - Face Detect Live View Movie – Evaluative metering
- Movie Exposure Compensation: ± 2 stops, in 1/3 or 1/2 stop increments
- Movie AE Lock: Not possible
- Movie Playback: Play; Slow Motion (playback speed adjustable); First Frame; Previous Frame; Next Frame; Last Frame; Sound Volume (6 levels, including volume off)

Live View Function

- Viewing Options:
 - Camera's LCD monitor
 - Computer monitor, tethered via USB cable and Canon EOS Utility software
 - Computer monitor, wirelessly via WFT-E3/E3A
- Image Display:
 - Stills
 - Stills with Exposure Simulation
 - Movies
- Manual Focus: Viewed on LCD monitor, with option to magnify 5x or 10x
- Auto Focus: Possible
 - “Quick Mode” 9 point phase-difference AF (mirror drops momentarily, AF via AF sensor)
 - “Live Mode” (uninterrupted Live View; Single point, contrast-based off of imaging sensor)
 - “Face Detection Live Mode” (Face detection, contrast-based)
- Shutter response in Live View: Approx. 73 milliseconds
- Live View Frame Rate: 30 fps
- Silent mode Live View Shooting: Yes (Mode 1, and Mode 2)
- Grid Line Display: 2 – Grid Displays available

LCD Monitor

- LCD Monitor:** New Clear View LCD monitor
- 3.0 inch (diagonal) TFT color; approx. 100% coverage
 - Approx. 920,000-dot resolution
 - Approx. 170° viewing angle
 - Manually adjustable in 7 levels
- LCD Monitor Brightness Levels:**
- Auto LCD Brightness
 - Automatically adjusted by built-in light sensor (3 – brightness levels)
- Panel Coating:** Anti-reflection and anti-smudge coating

Autofocus System

- Number of AF Points:**
- 9 – Visible AF Points
 - 9 – AF points usable with all lenses f/5.6 and brighter
 - 1 – “High-precision” cross-type sensor at center, lenses f/2.8 and brighter
 - 6 – Assist-AF points
 - Not displayed in viewfinder. Assist-AF points function as needed when shooting in AI Servo AF.
 - 4 – Horizontal-line sensitive points usable with f/5.6 lenses and faster
 - 2 – High-precision, vertical-line sensitive points usable with lenses f/2.8 and faster

Light Source Detection Sensor provided to automatically compensate for the slight focus variations caused by the spectral characteristics of different light sources. Especially effective when shooting in artificial light sources.
- AF Point Selection:**
- Manual point selection
 - Using C.Fn III-3, AF point selection can be controlled with the Multi-controller, Main Dial, or Quick Control Dial
 - Automatic Selection
- AF Activation:** Pressing the shutter release halfway (SW-1), or pressing the “AF-ON” button
- AF Modes:**
- One Shot AF
 - AI Servo AF
 - AI Focus AF
 - Camera automatically switches between One Shot AF and AI Servo AF
- AF Sensitivity Range:** EV -0.5 ~ 18 (measured at 73°F and ISO 100)
- AF Microadjustment:** Adjust all by same amount, or Adjust by Lens

Exposure Control

Shutter Speeds:	30 seconds ~ 1/8000, plus Bulb; x-sync at 1/250 sec.
ISO Range:	ISO 100 ~ 6400; (Expandable – L:50; H1: 12,800; H2: 25,600)
Auto ISO:	ISO 100 ~ 3200
Exposure Modes:	Manual, Aperture Priority (Av), Shutter Priority (Tv), Program AE, and camera user (C1, C2 settings)
Full Auto Modes:	Green Zone, Portrait, Landscape, Close-up, Action, Night Portrait, Flash Off, Creative Auto
Metering:	35-zone metering sensor <ul style="list-style-type: none"> • Evaluative Metering (linked to active AF points) • Center-weighted Metering • Partial Metering (Center, approx. 8% of viewfinder) • Spot Metering (Center, approx. 3.5% of viewfinder area)
Metering Range:	EV 1 ~ 20 (all patterns at normal temperatures)
Exposure Compensation:	Possible in P, Tv, Av, and A-DEP Exposure Modes ± up to 2 stops, in 1/2 or 1/3-stop increments
Auto Exposure Bracketing:	Possible in P, Tv, Av, and A-DEP Exposure Modes ± up to 2 stops, in 1/2 or 1/3-stop increments
Automatic Image Correction Tools:	<ul style="list-style-type: none"> • Auto correction of Lens Periphery Illumination <ul style="list-style-type: none"> ▪ Correction for specific lenses can be registered in camera using Canon EOS Utility software • Auto Light Optimizer • Highlight Tone Priority Mode

Flash

Compatible Flashes:	All Canon EX-series Speedlites
Camera Menu Sets Flash:	Yes (580EX II, and 430EX II only)
E-TTL II Flash Metering:	Flash metering NOT linked to active AF point, Distance from compatible EF lenses now used Fully compatible
Wireless E-TTL:	Up to ±2 stops in 1/3 or 1/2 stop increments
Flash Exposure Compensation:	N/A
Built-in Flash:	<ul style="list-style-type: none"> • Accessory shoe: X-sync contact (syncs at 1/200 sec. or slower)
Sync Contacts:	<ul style="list-style-type: none"> • PC terminal <ul style="list-style-type: none"> ▪ X-sync at 1/125 sec Sync duration: Since large studio flash systems have different flash duration times, tests should be done beforehand to determine precise sync speed (1/125 ~ 1/30 sec.) ▪ No polarity
	Both the accessory shoe and PC terminal can be used simultaneously

Viewfinder

Viewfinder:	Fixed pentaprism Newly-designed viewfinder optics, now larger, easier to see, and clearer than EOS 5D model
	<ul style="list-style-type: none"> • Coverage: approx. 98% • Magnification: approx. 0.71x • Eye point: 21 mm (from eyepiece lens center)
Focus Screen(s):	<ul style="list-style-type: none"> • Eg-A provided as standard <p>Available options:</p> <ul style="list-style-type: none"> ▪ Eg-D: Precision Matte w/Grid Lines ▪ Eg-S: Super Precision Matte
Eyepiece Accessories:	<ul style="list-style-type: none"> • Eyecup Eb • Rubber Frame Eb • Eyepiece Extender EP-EX15 • E-series Dioptic Adjustment Lenses
Dioptic Adjustment:	Adjustable from: -3.0 ~ +1.0
Viewfinder Blackout:	Time Approx. 145 ms, at 1/60 sec. and faster speeds
New Viewfinder Information:	ISO speed, Monochrome Shooting, Battery Check, D+ (expanded dynamic range using Highlight Tone Priority Mode)

Image Control

Color Space:	sRGB, and Adobe RGB 1998
White Balance:	Manual control range 2500°K ~ 10,000°K Custom WB range 2000°K ~ 10,000°K Auto WB range 3000°K ~ 7000°K
White Balance Correction:	±9 levels Blue/Amber shift ±9 levels Magenta/Green shift
White Balance Bracketing:	Yes
Picture Style:	6 – Standard, Portrait, Landscape, Neutral, Faithful, Monochrome 3 – User sets available

Interface

Computer Connection:	High-speed USB, mini-B port
Wireless Transmitter:	WFT-E4/E4A
	<ul style="list-style-type: none"> • Serial USB • 802.11b/g wireless networks • Ethernet

- Remote Control:**
- Canon N3-type terminal
 - Remote Control Sensor below self-timer lamp receives signals from optional Canon RC-1/RC5 Remote Controllers
 - Sensor activated when drive mode is set to either 10 sec. or 2 sec. self-timer settings
- Audio/Video Terminals:**
- HDMI-mini Out
 - Audio/Video Out
 - Uses STV-150N Stereo Video Cable – included NTSC/PAL
 - External Microphone Input
 - 3.5mm dia. Plug compatible with commercially available external microphones

Direct Printing

- Compatibility:** PictBridge
- BubbleJet Direct, and CP Direct not supported
- Compatible Images:** RAW and JPEG images
- Only RAW images captured by the EOS 5D Mark II can be printed.
 - Movies can not be printed
- Preview Controls on camera's LCD:** Paper size, Paper types, Printing effects, Layout, Trimming, Tilt-correction ($\pm 10^\circ$ in 0.5° increments), Date and Time imprinting
- Connection to Printer:** USB
- DPOF Image Marking:** Complies with DPOF version 1.1 specifications

Power Supply

- Battery:** 1 – Canon LP-E6
- Shooting Capacity:** Approx. 850 shots at 73F/23C (according to CIPA standard)
- AC Charger Units:** Either LC-E6, or LC-E6E
- Car Charger Unit:** Optional: CBC-E6
- AC Adapter:** Optional: AC Adapter Kit ACK-E6
- Battery Grip:** Optional: BG-E6
- 2 – Canon LP-E6 Battery Packs can be used, or
 - 6 – AA size batteries with supplied insert
- Date/Time Back-up Battery:** Lithium-ion CR1616 button battery (approx. life: 5 years)
- Stored in compartment below the terminal area

Body

Exterior Material:	Magnesium alloy
Chassis Material:	Stainless steel chassis, and Polycarbonate with glass fiber mirror box
Lens Mount:	Canon EF Lens mount; Metal
Lens Compatibility:	All Canon EF lenses
Operating Temperature Range:	0° ~ 40° C 32° ~ 104° F
Operating Humidity:	85% or less
Dimensions (W x H x D):	152 x 113.5 x 75 mm 6.0 x 4.5x 3.0 inches
Weight (without battery or memory card):	810 g. / 28.6 oz.

EF 24mm f/1.4L II USM Wide Angle lens

Optics

Focal Length:	24mm
Optical construction:	13 elements in 10 groups
Aspherical lens elements:	2 (2nd and 13th elements)
Ultra-low Dispersion glass elements:	2 (4th and 9th elements)
Multi-coating:	Super Spectra coating (special new coating for 1st element)
Aperture:	8 blades with circular shape
Aperture ratio:	1:1.4

Angle of view at infinity

Diagonal (43.2mm):	84 degrees
Vertical (24mm):	53 degrees
Horizontal (36mm):	74 degrees

Focusing

AF motor:	Ring USM
AF speed:	0.49 sec
AF drive noise:	40 dB or lower (based on Canon's measuring standards)
Focusing system:	Rear focusing system, with focusing cam
Manual focus:	Enabled with focus mode switch and focusing ring
Minimum focus:	0.25 m (0.82 ft)
Field of view:	139 x 208mm
Maximum magnification:	0.17x

Diaphragm

Aperture range:	f/1.4 to f/22 (for 1/3 stop increments also)
Number of diaphragm blades:	8 (circular aperture)
Aperture control:	Pulse control with EMD (enabled simultaneously during autofocus)

Accessories

Filter size:	77mm
Lens hood:	EW-83K petal-type, equipped with a two-claw removable dedicated bayonet hood attachable in reverse
Lens case:	LP1319, accommodates the lens, lens cap, and dust cap
Dust cap:	Lens dust cap E
Extension tube:	EF12 II

Dimensions and Weight

Length/width:	83.5 x 86.9mm (3.3 x 3.4in)
Weight:	650g (1.4 lbs.)

EF-S 18-200mm f/3.5-5.6 IS Wide Angle-Telephoto Zoom lens

Optics

Focal Length:	18-200mm (equivalent to 29-320mm in 35mm format) only compatible with EOS Digital cameras that have an APS-C size sensor.
Optical construction:	16 elements in 12 groups
Aspherical lens elements:	2 (8th and 15th elements)
Ultra-low Dispersion glass elements:	2 (2nd and 14th elements)
Multi-coating:	Super Spectra coating used on all elements
Aperture:	6 blades with circular shape

Image Stabilizer

Stabilizer unit:	Parallel shifting of compensation optics
Shake detection:	Via gyro sensors (1 sensor each for yaw and pitch)
IS activation:	Turned on with the IS switch and activated by pressing the shutter button halfway
Mode Selection:	Switches automatically between Normal and Panning modes
Tripod operation:	Has a function that prevents the IS from being operated incorrectly when mounted on a tripod

Autofocus

AF motor:	Gear driven by DC motor
Manual focus:	Enabled with focus mode switch and focusing ring
Minimum focus:	1.5 feet (0.45m)
Maximum magnification:	0.05x (18mm), 0.24x (200mm)

Diaphragm

Aperture range:	f/3.5-5.6 (marked on lens barrel), to f/22-38 (f/22-38 for 1/2 stop increments)
Number of diaphragm blades:	6 (circular aperture)
Aperture control:	Pulse control with EMD (enabled simultaneously during autofocus)

Accessories

Filter size:	72mm
Lens hood:	EW-78D petal-type, equipped with a two-claw bayonet-mount. The inside of the hood is treated with a coating for a greater anti reflective effect.
Lens case:	LP1116 flap fastening soft case

Dimensions and Weight

Length:	102mm
Weight:	595g (1.3lbs)



EOS 50D Comparison Chart

	EOS 50D	EOS 40D	Nikon D300	Pentax K20D	Sony A700	Olympus E-3
Imaging Sensor						
Effective Pixels	15.1 (4752 x 3168)	10.1 (3888 x 2592)	12.3 (4288 x 2848)	14.6 (4672 x 3120)	12.2 (4288 x 2856)	10.1 (3648 x 2736)
Image Sensor	Canon CMOS		CMOS	CMOS	CMOS	CMOS
Sensor Size	1.6x		1.5x	1.5x	1.5x	N/A (approx. 2x that of 35mm)
Aspect Ratio	3:2 ratio		3.2 ratio	3.2 ratio	3.2 ratio	4:3 ratio
Cleaning System	EOS Integrated Cleaning System		Yes	Yes	Yes	Yes
Image Processing						
Processing Engine	Canon DIGIC 4	Canon DIGIC III	Nikon EXPEED	PRIME	BIONZ	—
A/D Conversion (bit depth)	14 bit		12 bit (14 bit available at reduced speed performance)	12 bit	—	12 bit
RAW File Resolution Options	RAW — 4752 x 3168 sRAW1 — 3267 x 2178 sRAW2 — 2376 x 1584	RAW — 3888 x 2592 sRAW1 — 1936 x 1288	4288 x 2848	4672 x 3120	4288 x 2856	2648 x 2736
Dynamic Range Expansion	Yes, Highlight Tone Priority		—	Yes	—	—
Brightness Auto Correction	Yes	No	Yes	—	Yes	Yes
Peripheral Illumination Correction	Yes	No	No	No	No	Yes
Noise Reduction	Long Exposure High ISO (4 levels)	Long Exposure High ISO	Long Exposure High ISO (3 levels)	Long Exposure High ISO (4 levels)	Long Exposure High ISO (3 levels)	Long Exposure High ISO
Recording Media						
Media Type	CF		CF	SD, SDHC	CF, Memory Stick	CF, xD
UDMA Compatibility	Yes	No	Yes	—	Yes	Yes
External Media Connection	Yes via Canon WFT-E3A unit		No	No	No	No
Folder creation/selection by user	Yes	No	Yes	No	Yes	No
Image Quality Adjustment						
White Balance range	2500 ~ 10,000K°		2500 ~ 10,000K°	—	2500 ~ 9900K°	2000 ~ 14,000K°
White Balance Shift	±9 levels Blue/Amber Bias, ±9 levels Magenta/Green bias		Yes	Yes	Yes	Yes
White Balance Bracketing	Yes		Yes	Yes	Yes	Yes
Image Quality Adjustment	Picture Styles, 6 + 3 user sets		Yes, 4 Picture Controls	No	Yes	Yes
Viewfinder						
Coverage	95%		100%	95%	95%	100%
Magnification	0.95x		0.94x	0.95x	0.90x	1.15x
Eye-point	22		19.5	—	25	20
Dioptic Adjustment	-3 ~ +1		-2 ~ +1	-2.5 ~ +1.5	-3 ~ +1	-3 ~ +1
Interchangeable focusing screens	Yes		No	Yes	Yes	Yes
Live View Shooting						
AF Modes	Quick focus AF Live contrast-based AF Face-detect Live AF	Quick Focus	Quick Live	Quick	No	Quick
Silent Shooting	Yes		No	No		No
Grid Display	2	1	1	1		1
Remote Live View	Tethered via USB Wireless tethered via WFT-E3a unit		Tethered using optional software	No		No
Autofocus						
AF Points	9 — cross-type points sensitive to f/5.6 1 — Diagonal high-precision cross-type center point		51 15 cross-type points	11 9 cross-types	11 1 cross-type	11 All cross type
Brightness range	EV -0.5 ~ 18		EV -1 ~ 19	EV 0 ~ 21	EV 0 ~ 18	EV -2 ~ 19
AF Modes	One Shot AF, AI Servo AF, AI Focus AF		One Shot, Servo	One Shot, Servo	One Shot, Servo	One Shot, Servo
Fine Adjustment	AF Microadjustment	No	Yes	No	No	—

	EOS 50D	EOS 40D	Nikon D300	Pentax K20D	Sony A700	Olympus E-3
Exposure Control						
Metering Zones	35		1005	16	40	49
Metering Range	EV 1 ~ 20		EV 0 ~ 20	EV 0 ~ 21	EV 0 ~ 20	Ev 0 ~ 20
Metering Modes	Evaluative		Matrix	16 segment pattern	Multi-segment	Multi-patter
	Center Weighted Partial (center, approx. 9% of viewfinder) Spot (center, approx 3.8% of viewfinder)		Center-weighted Spot	Center-weighted Spot	Center-weighted Spot	Center-weighted Spot Spot Highlight control Spot Shadow control
Creative Auto Mode	Yes	No	No	No	No	No
ISO Speed range	100 ~ 3200 H1: 6400 H2: 12,800	100 ~ 1600 Hi: 3200	200 ~ 3200 L:100, Hi: 6400	100 ~ 3200 Hi: 6400	100 ~ 3200 Hi: 6400	100 ~ 3200
Shutter						
Speed range	1/8000 ~ 30 sec., BULB	1/4000 ~ 30 sec., BULB	1/8000 ~ 30 sec., BULB	1/4000 ~ 30 sec., BULB	1/8000 ~ 30 sec., BULB	1/8000 ~ 30 sec., BULB
X-sync	1/250 sec.		1/250 sec.	1/180 sec.	1/250 sec. w/o Steady Shot 1/200 w/ Steady Shot	1/250 sec.
Shutter response speed (lag)	59 ms		—	—	—	—
Start-up Time	0.10 sec.	0.15 sec.	0.13 sec.	—	—	—
Drive						
Continuous Shooting (fps)	6.3 fps	6.4 fps (Based on new CIPA 2007 guidelines)	6 fps (Reduced at 14 bit mode to 2.5 fps)	3 fps	5 fps	5 fps
Maximum Burst	60 JPEG (large/fine) 90 JPEG w/ UDMA cards 17 RAW 11 RAW + JPEG	75 JPEG (large/fine) 17 RAW 14 RAW + JPEG	43 JPEG (large/fine) 21 RAW	38 JPEG 14 RAW	— JPEG 8 RAW 17 cRAW (compressed RAW mode)	— JPEG 16 RAW
Built-in Flash						
Guide Number (m)	13		12	13	12	13
Flash Coverage	17 mm		18 mm	28 mm	16 mm	14 mm
LCD Monitor						
Screen size	3.0 inches		3.0 inches	2.7 inches	3.0 inches	2.5 inches
Resolution (Dots)	920,000	230,000	920,000	230,000	920,000	230,000
Angle of View	160°	140°	170°	160°	—	176°
Flip-out	—	—	—	—	—	Yes
Anti-reflection / antismudge coating	Yes / Yes	—	—	—	—	—
HDMI Output	Yes	—	Yes	—	Yes	—
Accessories						
Wireless LAN / GPS compatibility	Yes With Canon WFT-E3A		Yes w/ WT-4	—	—	—
Other						
Image Stabilization	Optical in Lens		Optical in Lens	Body Based	Body Based	Body Based
Appending user Copyright info	Yes	No	Ability for user text input, but not specifically copyright information	No	No	No
Quick Control Screen	Yes	No	No	No	Yes	Yes
Original image verification data	Yes With optional Canon OSK-E3 software kit		Yes With optional software	No	No	No
Dimensions (W x H x D mm)	145.5 x 107.8 x 73.5		147 x 114 x 74	141.5 x 1.1 x 70	141.5 x 104.8 x 79.7	142.5 x 116.5 x 74.5
Weight (g)	730	740	825	715	690	810

EOS 5D Mark II Comparison Chart

	EOS 5D Mark II	EOS 5D	Nikon D700	Nikon D3	Nikon D90	Sony A900
Imaging Sensor						
Effective Pixels	21.1	12.8	12.1		12.3	24.6
Image Sensor	Canon CMOS Sensor		CMOS			CMOS
Sensor Size	1x 24 x 36mm Full Frame		1x – in FX Mode 1.5x – in DX Mode		1.5x	1x
Aspect Ratio	3:2 Ratio		3:2			3:2
Cleaning System	EOS Integrated Cleaning System		Self Clean Function	No	Self Clean Function	Self clean via CCD Shift unit
Image Processing						
Processing Engine	Canon DIGIC 4	Canon DIGIC II	EXPEED			Dual BIONZ
A/D Conversion (bit depth)	14 bit	12 bit	12 bit, 14 bit		12 bit	12 bit
RAW File Resolution Options	RAW – 5616 x 3744 sRAW1 – 3861 x 2574 sRAW2 – 2784 x 1856	RAW – 4368 x 2912	RAW – 4256 x 2832		RAW – 4288 x 2848	RAW 6048 x 4032
Dynamic Range Expansion	Yes Highlight Tone Priority	No	Yes			Yes
Brightness Auto Correction	Yes	No	No			No
Peripheral Illumination Correction	Yes	No	No			No
Noise Reduction	Long Exposure High ISO (4 levels)	Long Exposure	Long Exposure High ISO (4 levels)	Long Exposure High ISO (3 levels)		Long Exposure High ISO 6
Performance						
Continuous Shooting (fps)	3.9 fps	3.0 fps	5 fps 8.0 fps w/ optional battery pack	9 fps	4.5 fps	5 fps
Maximum Burst JPEG based on Large/ Fine setting	78 – JPEG (310 using UDMA cards) 13 – RAW (14 UDMA) 8 – RAW + JPEG (8 UDMA)	60 – JPEG 17 – RAW 12 – RAW + JPEG			50 – JEG 7 – RAW 105 – JPEG (Fine)	12 – RAW 25 – Compressed RAW 11 – RAW + JPEG
Shutter Speeds	30 seconds ~ 1/8000, plus bulb		30 seconds ~ 1/8000, plus bulb		30 seconds ~ 1/4000, plus bulb	30 seconds ~ 1/8000, plus bulb
Shutter Actuation Rating	150,000 frames	100,000 frames	150,000 frames	300,000 frames	100,000 frames	100,000 frames
Flash Sync Speed	Up to 1/200 sec		1/250sec.		1/200 sec.	1/250 (1/200 in steady shot mode)
Start-up Time	0.1 sec.	0.2 sec.	0.12 sec.		0.15 sec.	0.183
Shutter Response Speed (lag)	TBD	0.75 sec.	40 ms.			
Movie Shooting and Playback						
Recording Format	MOV MPEG 4*2 Video: H.264 Sound: Linear PCM	No	No	No	AVI Motion JPEG	No
Movie Recording Size	Full HD – 1920 x 1080 (16:9) SD/VGA – 640 x 480 (4:3)				720p HD – 1280 x 720 (16:9) SD VGA – 640 x 480 (4:3) SD QVGA – 320 x 216 (4:3)	
Frame Rate	30 fps				24 fps	
Still Capture Option during Movie Shooting	Yes Movie continues after still frame capture Approx. 1/2 sec. pause in video while still frame is captured				No Movie mode is exited for still frame capture, and requires manual reactivation of movie recording	
Sound	Built-in mic – Monaural External (optional) – Stereo				Built-in mic Monaural only No option for external audio input	

	EOS 5D Mark II	EOS 5D	Nikon D700	Nikon D3	Nikon D90	Sony A900
Continuous Movie Record Time	Movie clips limited to 4GB in length Approx. Time 12 minutes – Full HD-video 1080p 24 minutes – SD-video	No	No	No	5 minutes in 720p HD mode	No
Focus Modes in Video	Autofocus Quick Mode Live Mode Face Detect Live Mode Manual Focus				Manual focus only	
Live View						
AF Modes	Autofocus Quick Mode Live Mode Face Detect Live Mode Manual 5x, 10x magnification modes	No	Quick Mode Contrast AF in Tripod Mode		Wide -area AF Normal-area AF Face Priority AF	No
Silent Shooting	Yes		No		No	
Grid Display	2 Grid displays available				1	
Remote Live View	Tethered via USB and included software; Wireless tethered via WFT-E3a unit		Yes Using optional software			
LCD Monitor						
Screen Size	Clear View LCD Monitor 3.0 inches	2.5 inches		3.0 inches		3.0 inches
Resolution (dots)	920,000	230,000		920,000		921,000
Angle of View	170°	170°		170°		
Anti-smudge / Anti-reflection	Yes	No		No		No
HDMI mini Output	Yes	No		Yes		Yes
Autofocus						
AF Points	9 – AF Points 9 – AF points usable with all lenses f/5.6 and brighter 1 – “High-precision” cross-type sensor at center, lenses f/2.8 and brighter 6 – Assist-AF points (Not displayed in viewfinder – used in AI Servo AF Tracking) 4 – Horizontal-line sensitive points usable with f/5.6 lenses and faster 2 – High-precision, vertical-line sensitive points usable with lenses f/2.8 and faster		51 – AF Points (15 cross-type sensors grouped in center of frame)		11 – AF Points 1 – cross -type sensor	9 – AF Points 10 – Assist points
Brightness Range	EV -0.5 ~ 18		EV -1 ~ 19			EV 0 ~ 18
AF Modes	One Shot AF AI Servo AF AI Focus AF		Single Servo AF Continuous Servo AF		Single Point AF Dynamic area AF Auto-area AF 3D Tracking AF (11 point)	Single Shot AF Continuous AF Automatic AF
Fine Adjustment	AF Micro Adjustment	No	Yes		No	AF Micro Adjustment
Exposure Control						
Metering Zones	35 –zone metering sensor		1005 RGB Sensor			40 segment honeycomb
Metering Range	EV 1 ~ 20		EV 0 ~ 20			EV 0 ~ 20
Metering Modes	Evaluative Metering, Center-weighted Partial Meter (approx. 8% of finder) Spot Meter (approx. 3.5% of finder)		3D Color Matrix Variable Center-weighted Spot			Multi-segment Center-weighted Spot
ISO Speed Range	ISO 100 ~ 6400 Expanded range: L: 50 H1: 12,800 H2: 25,600	ISO 100 ~ 1600 Expanded range: L: 50; H: 3200	200 ~ 6400 (Expanded range: 100, 12800, 25600)		200 ~ 3200 (Expanded range: 100, 6400)	200 ~ 3200 (Expanded: 100, 6400)

	EOS 5D Mark II	EOS 5D	Nikon D700	Nikon D3	Nikon D90	Sony A900
Recording Media						
Media Type	CFType I and II	CFType I and II	CF	CF (2 – card slots)	SD/SDHC	CF, Memory Stick
UDMA Compatibility	Yes	No	Yes		N/A	Yes
External Media Connection	Yes Via WFT-E4/E4A unit	No	No		No	No
Folder creation/ selectio by user	Yes	No	No			No
Image Quality Adjustment						
White Balance Range	2000°K ~ 10,000°K	2800°K ~ 10,000°K	2500°K ~ 10,000°K			2500°K ~ 9900°K
White Balance Shift	±9 levels Blue/Amber Shift ±9 levels Magenta/Green Shift		Yes			Yes
White Balance Bracketing	Yes		Yes			Yes
Image Quality Adjustment	Picture Styles 6 + 3 user sets		4 Picture Control Options			Yes Color Modes Image Parameters
Viewfinder						
Coverage (approx.)	98%	96%	95%	100%	96%	100%
Magnification	0.71x	0.71x	0.72x	0.74x		0.74x
Eye-point	21mm	20mm	18mm		19.5mm	20mm
Dioptric Adjustment	Adjustable -3.0 ~ +1.0		-2.0 ~ +1	-3.0 ~ +1		-3.0 ~ +1
Interchangeable Focusing Screens	Yes With Eg-series screens	Yes With Ee-series screens	No	Yes	No	Yes
Accessories						
Wireless Unit Functionality	WFT-E4/E4A Unit FTP Mode PTP Mode HTTP Mode GPS input External Drive Output Ethernet Com Port	WFT-E1A FTP Mode Ethernet Com Port	WT-4A FTP PTP Thumbnail view Ethernet Port		Aftermarket option	No
Other						
Appending User Copyright Info	Yes	No	Text EXIF Input			No
Original Image Verification Date	Yes With optional Canon OSK-E3 software kit		Yes With optional software			No
Dimensions (W x H x D mm)	152 x 113.5 x 75 mm	152 x 113 x 75 mm	147 x 123 x 77 mm	159.5 x 157 x 87.5 mm	132 x 103 x 77 mm	156 x 117 x 82mm
Weight (g)	810 g.	810 g.	995 g.	1240 g.	620 g.	850 g.



Canon's EOS 5D Mark II and EOS 50D are two of the most refined photographic instruments available for serious photographers. Yet, while both of these cameras share a multitude of high-performance features such as rugged, weather-resistant bodies, super-sharp 3.0-inch LCD monitors, advanced image quality controls, and an extensive software package, they have distinctive capabilities designed to appeal to a broad cross-section of advanced amateur and professional photographers.

For the price, no other DSLR comes close to rivaling the image quality and full-frame convenience offered by the EOS 5D Mark II. This 21.1-megapixel, full-frame camera can reliably handle many professional assignments while delivering the superb image quality, shadow and highlight detail, low light performance, and Live View functionality of Canon's flagship EOS-1Ds Mark III—all at less than half the price. In addition, the EOS 5D Mark II's unique 1080p Full HD video recording capability sets this camera apart from the competition and bridges the technological gap between advanced digital still cameras and HD camcorders by offering both capabilities in one device. Now, traditional wedding, event, sports, and nature photographers can increase their value to prospective clients by offering them both still and video services without being forced to invest in a high-end HD camcorder or an assistant to help carry all the extra video gear. Alternatively, professional videographers will be drawn to the EOS 5D Mark II's unique depth of field control and its ability to capture true wide and ultra wide HD video (along with stereo sound) directly onto convenient CF cards.

The EOS 50D offers exceptional image quality and performance for its price and could be the ideal backup camera for pros shooting with either the EOS 5D Mark II or the EOS-1Ds Mark III. But advanced amateur and part-time pros will also appreciate the EOS 50D for its high speed burst mode, super-fast and sensitive AF system, advanced metering and image processing capabilities, and sophisticated custom controls borrowed from the professional EOS-1D series. Photographers moving up from older and lower-priced Canon DSLRs will also appreciate the EOS 50D's compatibility with their existing Canon EF-S lenses, and they'll be better able to appreciate the higher performance, precision, and durability built into the EOS 50D, as well as its advanced battery-grip and wireless accessories.

Beyond the multiple benefits that both the EOS 5D Mark II and the EOS 50D bring to DSLR users, these new cameras provide ample evidence of Canon's unsurpassed ability to continually improve its product quality and feature levels while maintaining the company's leadership role in the increasingly competitive digital imaging industry.